

EcosimPro

Modelling and Simulation Software



THERMAL LIBRARY

The THERMAL library contains a group of components that facilitate easy modelling of thermal networks and its ability to interact with other libraries makes it possible to model multidisciplinary systems.

EcosimPro

EcosimPro is a powerful **modelling** and **simulation** tool with a simple interface that makes the design of **multidisciplinary** dynamic systems easy and intuitive using graphic diagrams.

For users with specific needs, EcosimPro provides an object-oriented non-causal approach towards creating reusable component libraries and is based on very powerful symbolic and numerical methods capable of processing **complex systems** represented by differential-algebraic equations (DAE) or ordinary-differential equations (ODE) and discrete events. However, low-level problems such as programming calls with numerical solvers, equation handling, etc, are solved automatically or using simple wizards.

Features

THERMAL is a standard library which is supplied with EcosimPro and contains components to predict **temperature distributions** and **heat flows** in systems and devices using the thermal network method.

The thermal network method is also known as the lumped parameter method or the resistance/capacity method. It is essentially a finite difference method and entails modelling a continuous medium as a discrete thermal network of nodes representing the capacitance of the system linked by conductors representing its conductance.

Lumped parameter models are easily built. A thermal system with complex geometries can be replaced by a series of heat capacities and conductors (one-dimensional heat transfer) if a very detailed temperature distribution within the system is not required.

Using **drag & drop** methodology, the user can quickly create a diagram of the mechanical system to be analysed, the representation of which is very similar to the physical system. The capabilities of the library are vast, since customised

components can be developed from the available components as a function of the modelling needs.

Thanks to EcosimPro's features, libraries can be built that are easy to **configure** and **extend**, adding any components and characteristics as needed. This can be done graphically through a simple, user friendly interface, or through EcosimPro's **object-oriented language** which makes it possible to re-use existing codes.

One of the library's biggest advantages is the possibility of its use in the multidisciplinary facet of EcosimPro. This means that we can jointly study, for example, hydraulic systems or energy generation processes, such as combined cycle plants, and the dynamic behaviour of heat transfer through different geometrics and materials. This way, an overall study of the system is obtained with minimal design time.

Either steady-state or transient analyses can be handled with this library. The heat transfer modes that can be considered in the thermal model are conduction, radiation and natural convection. Material properties such as specific heat or conductivity may also vary with temperature.



The components

Depending on whether temperature or heat flow is calculated, most of the components of this library can be classified as:

- **Capacitive components (C):** they have thermal inertia, since in their formulation the temperature is calculated in the component port as a state variable: boundary thermal node, diffusive thermal node, thermal wall...
- **Resistive components (R):** in this case, the thermal flow, and not the temperature, is calculated as a state variable: plate divided into a number of longitudinal and



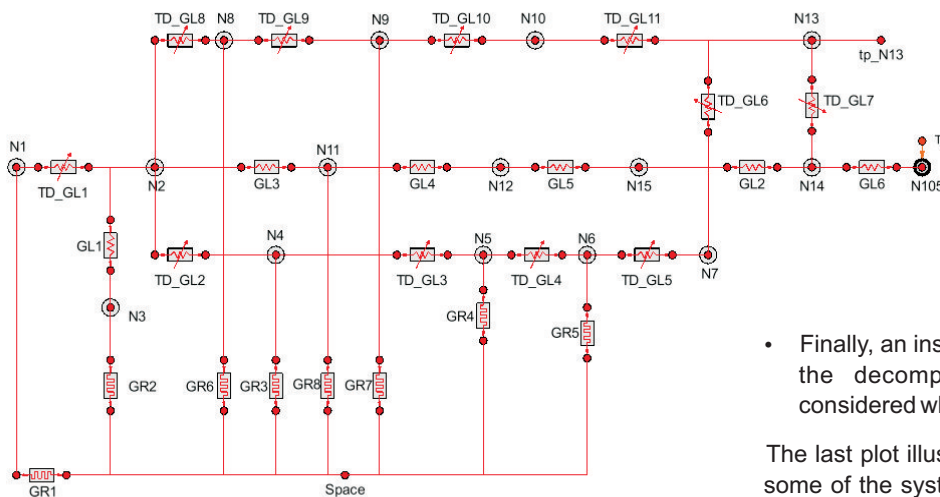

transversal nodes, linear conductor, radioactive conductor

In this way, the construction of thermal networks through this library complies with the following basic rule: components having ports of the types described above (C and R) must be connected to each other in an alternating arrangement represented by the string C-R-C-R-C.

Finally, another important aspect of this library is the calculation of thermal properties based on the interpolation in external data contained in files which are provided. This enables the user to add his own files of properties. Properties for a group of materials (aluminium, carbon, carbon steel, copper, etc) are also available.

Example

The following example consists of a system that represents the model of a hydrazine thruster.

A thermal mesh representing the real process has been built in order to model it with the THERMAL library. The diagram below illustrates the behaviour of a hydrazine thruster.

The components used in this case are the following::

- Nodes: represented by the components N1, N2, etc. They model the heat transfer in the different parts of the thruster (nozzle, head plate, injection tube, cartridge heat, valve, decomposition chamber, space, etc)
- Conductors: represented by the components GR1, GL1, GR2, GL3, etc, each one with their respective conductivity and radioactivity coefficients

The experiment carried out is as follows:

- First, a steady state at time zero is calculated
- When the simulation time of 100 seconds is reached, the impressed heat value is increased in nodes 14 and 15 that represent a valve flange and a valve body, respectively (see first figure)
- Finally, an instantaneous increase in the temperature of the decomposition chamber (N2 component) is considered when reaching 1500 s (see second plot)

The last plot illustrates the evolution of the temperature of some of the system nodes. It shows how the temperature profile in all nodes increases as the impressed heat of two of the nodes increases.

This temperature profile is modified again with the instantaneous increase in the decomposition chamber temperature. The temperature in the different components continues to increase and, with time, reaches a new steady state.

