

EcosimPro

Modelling and Simulation Software



PREDICTIVE CONTROL LIBRARY

The PREDICTIVE CONTROL library incorporates the multivariate linear predictive controllers DMC and GPC with restrictions including their treatment, feasibility management, reconfiguration of the structure and economical set.

EcosimPro

EcosimPro is a powerful **modelling** and **simulation** tool with a simple interface that makes the design of **multidisciplinary** dynamic systems easy and intuitive using graphic diagrams.

For users with specific needs, EcosimPro provides an object-oriented, non-causal approach towards creating reusable component libraries and is based on very powerful symbolic and numerical methods capable of processing **complex systems** represented by differential-algebraic equations (DAE) or ordinary-differential equations (ODE) and discrete events. However, low-level problems such as programming calls with numerical solvers, equation handling, etc, are solved automatically or using simple wizards.

Features

PREDICTIVE CONTROL is a professional library for modelling advanced control systems. The main idea was to develop **robust control algorithms** based on simple, measurable process models, providing acceptable results along with constraints, noises and parameter uncertainties. Using predicted **future information**, these algorithms could provide better control performance compared to the usual PID control, especially in the case of known reference signals and with a great amount of plant dead time. The philosophy behind this is that by using more information, better decisions could be made. A goal is to calculate the actual and the subsequent control signals, minimising the quadratic deviation of the reference signal and the output signal for a given future time horizon. According to the receding **horizon control strategy** only the first control signal is used at the process input, and in the next sampling point the procedure is repeated. Nowadays, it is declared that predictive control algorithms are the **second most used algorithms** in the process industry - besides PID control. Predictive control algorithms have been developed mainly

for linear plants. Predictive control also seems to be a promising technique in the nonlinear environment.

The library implements two linear predictive control algorithms, DMC and GPC, which enables you to select the most appropriate method for the type of process and the control objectives of each application.

It offers the **management of non-feasibility** situations and automatic reconfiguration when variable states are modified.

Simultaneously with the controller, the tool also implements a **setpoint optimiser** which, using the same models, enables you to calculate in line the optimal operation point of the process from an economical point of view which makes the implementation of advanced plant control more attractive. An interesting feature of the optimiser is its capacity to **penalise** the values of the controls; this is not available in most commercial controllers and was included in order to increase the number of problems tackled.

The implemented software is of a **general type** so that, when correctly adjusted, it can be used to run in different continuous processes. Before use, the controller has to be configured on the screens where the variables to be used, the models that list them and a set of operation parameters are established.

The components

The library contains two elements::

- **DMC Controller (Dynamic Matrix Control):** predictive controller with the following advantages:

Model easy to implement. It can be definitive as a response to a jump or a transfer function



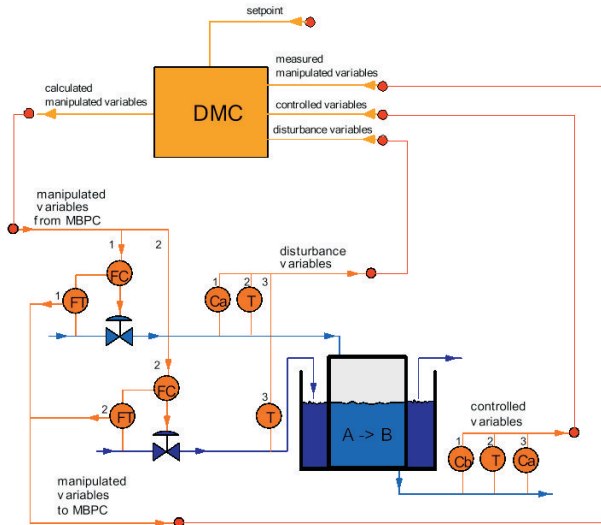

Attractive for industrial use, because training in its operation is not complicated

No need for any assumptions concerning the order of the model

However, it also has some disadvantages; the most important is that unstable processes in open circuits cannot be controlled

- **GPC Controller (Generalized Predictive Control):** this controller has turned out to be one of the most popular methods in both industrial and academic areas

In industrial applications, it showed good performance and some kind of solidity with regard to over-parameterisation or poorly known delays

It is effective in non-minimal phase or/and unstable in open-circuit plants

The model can be defined only as a transfer function

Example

This example consists in the control of the component CSTR: a liquid jacket reactor controlled by a DMC controller. This system provides a model with many coupled inputs.

The reactor is fed with a volume flow, F_I , a concentration of A, Ca_0 and a temperature, T_{I0} . The cooler is fed with a volume flow, F_r and a temperature Tr_0 .

The controlled variables are:

- the mass fraction of chemical component B, (C_b)
- the temperature of the reactor

- the mass fraction of chemical component A, (Ca)

The manipulated variables are:

- the inlet feed volume flow
- the cooler volume flow

The evolution of the controlled variables is illustrated in the graph. The three first plots show the modifications introduced in the controller references and how the corresponding controlled variables follow these values. In this respect, two modifications have been introduced: one ramp-shaped and the other step-shaped midway through the experiment. The DMC has guided the manipulated variables according to the shapes of plots three and four.

The last plot introduces a disturbance in the reactor power supply temperature. The DMC calculates the evolution of the manipulated variables so that the controlled variables do not divert from their reference.

Thanks to the use of a predictive controller, a multivariable system can be controlled easily and efficiently by calculating the optimal sequence of the manipulated variables.

