

# **Heat Transfer at Wall**

## **Experimental Characterisation in Supersonic Flows with Induced Condensation Phenomena**

Luca Boccaletto<sup>1</sup>  
Matteo Appolloni<sup>2</sup>  
Rogier Schonenborg<sup>3</sup>

<sup>1</sup> ESA-ESTEC, TEC-MPC, Keplerlaan 1, 2202 AZ Noordwijk, the Netherlands, Email: Luca.Boccaletto@esa.int

<sup>2</sup> ESA-ESTEC, TEC-TCE, Email: Matteo.Appolloni@esa.int

<sup>3</sup> Contractor for Schonenborg Space Engineering B.V. at ESA-ESTEC, TEC-MPC, Email: rogier.schonenborg@esa.int

### **ABSTRACT**

Accurate prediction of wall heat transfer in combustion chambers and nozzles is one of the major challenges for rocket engine designers.

For actively cooled combustors (regenerative or dump circuits), the heat transfer computation can be even more complex in case phase change phenomena occur at metallic walls on the coolant and/or hot gas side(s). Possible phase change phenomena can be sorted taking into account local operating conditions. Boiling and coking are the most dreaded phenomena on the coolant side. Possible phase change phenomena on hot gas side are; vapour condensation and even icing, in case local saturation/solidification conditions are achieved by overcooling.

The above described phenomena have already been observed in some rocket engines. In particular, during as well one-to-one scale as subscale test set ups, the existence of thermodynamic conditions promoting water vapour condensation at several locations of the thrust chamber has been confirmed.

A subscale - cold gas experiment is conducted in order to better characterise the heat exchange at wall when condensation/evaporation phenomena appear in a supersonic nozzle. The experimental outcome also provides data to validate numerical models.

The complete experimental set up consists of an instrumented cryogenically cooled 2-D nozzle (test article), readout equipment, visualization equipment, test bench, propellant, coolant and purge gas supply. This paper focuses on the design and manufacturing of the test article.

Condensation of the cold gas propellant is achieved by cooling the nozzle wall by activation and regulation of three cooling circuits through which liquid or gaseous Nitrogen flows.

Pressure and temperature sensors serve to collect pressure and temperature data at the three coolant inlet and outlet manifolds, as well as at the propellant inlet (chamber) and along the expanding propellant flow path. Data is visualized on screen (and stored) real time in order to regulate the various flows during the actual test runs.

During test runs, zoomed in high speed digital video footage is recorded to investigate the flow and to compare visual observations with measurement data after the experimental runs.

### **1. INTRODUCTION**

In order to get a better understanding of the condensation phenomena in cryogenically cooled nozzles, a test set-up is developed in which condensation of a supersonic flow can be induced along the nozzle by cooling one of the walls of a 2-D nozzle.

For simplicity and cost reduction, actual combustion is eliminated from the test set-up hence a cold gas propellant is used. Bottle-supplied ethylene is used as the propellant and bottle-supplied Nitrogen as the coolant.

Pressure sensors and temperature sensors serve to collect data at the inlet of the propellant and along the supersonic expanding flow path, as well as in the coolant inlet and outlet manifolds.

During test runs, high speed digital video footage is recorded in which condensation in the nozzle is visualized. In addition the overall experimental set up is recorded.

Tests are conducted in a bunker with separated readout room. Propellant as well as coolant and purge gas are vented towards the open air.

## 2. TEST ARTICLE COMPOSITION

The test article consists of a 2-D expansion nozzle with an inlet manifold, simulating the subsonic combustion chamber. One of the nozzle walls is cooled by nitrogen that flows through tubes embedded in the nozzle wall. The cooled nozzle wall is divided in three sections, each of them having a dedicated cooling circuit.

Each cooling circuit consists of an inlet manifold and outlet manifold that are connected to each other via the tubes that are embedded in the nozzle wall. The cooling circuits are nearly identical to each other.

The “combustion chamber”, supersonic nozzle and manifolds of the coolant circuits, are equipped with pressure and temperature sensors. In addition simple thermocouples are installed on various locations of the hardware for reference measurements. All sensors are connected via a patch panel and multiplexer to a laptop PC on which experimental data is visualized and stored.

The 2-D nozzle and cooling circuits are supported by a mounting structure that carries the loads for handling and testing.

The complete mass of the test article, excluding patch panel, multiplexer and PC, is approximately 10 kg. The overall external envelope of the test article measures approximately 200 mm x 200 mm x 200 mm. The individual components are described in more detail below.

## 3. 2-D EXPANSION NOZZLE

The 2-D expansion nozzle serves to expand the propellant under supersonic conditions. The objective of the tests is to explore as well conditions under which condensation occurs as to explore conditions under which condensation does not occur. In doing so, measurements of a wider regime can be analyzed and the condensation phenomena in this particular nozzle can be understood better. Afterwards, measurement interpretation and conclusions can be extrapolated towards different more complex nozzles. The nozzle design is such that condensation only takes place with activated cooling circuits. By regulating the coolant mass flow, it is possible to explore the thermodynamic conditions during which the condensation phenomenon occurs.

The propellant is fed by three flexible hoses, connected to the test article by three identical *Swagelok SS-1210-1-12* connectors (Figure 1). The overall cross section of the three connectors is much larger than the throat area, allowing

reduction of the ethylene velocity at the test article inlet. The three propellant flow paths come together in a single chamber, from where, after a 90° turn, the propellant enters the throat where the supersonic expansion commences.

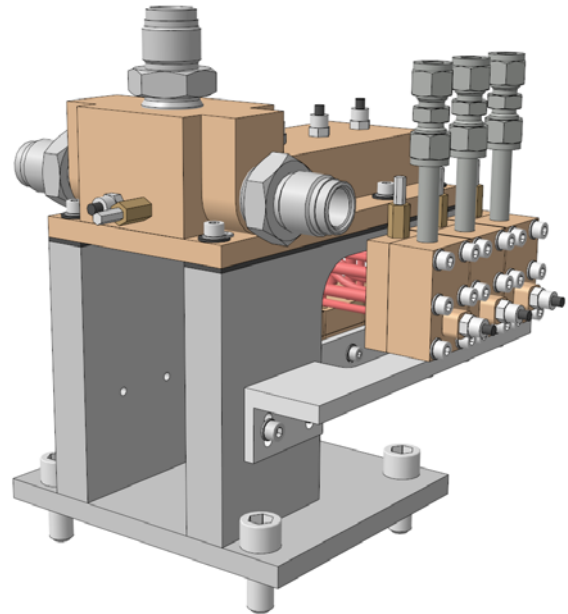

Figure 1: Back view of test article where three large propellant inlet connectors are clearly visible.

In order to achieve the desired thermodynamic conditions at the nozzle wall, three cooling circuits cool the lower nozzle wall. The coolant tubes are made in copper alloy (in red in the figures) and can clearly be identified in Figure 2. Coolant enters horizontally via the three tubes on the right and exits vertically via the three tubes on the left.

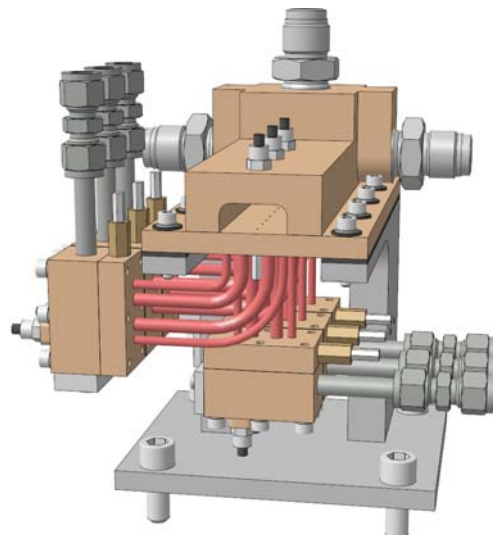

Figure 2: Front view of test article with clearly visible red coolant lines

Temperature and pressure data are gathered by various sensors in the inlet manifold (1 x pressure and 1 x temperature) as well as in the 2-D nozzle itself (3 x pressure and 9 x temperature). Figure 3 shows the line matrix of nine temperature sensors on the bottom of the 2-D nozzle and the matrix of three pressure sensors on the top.

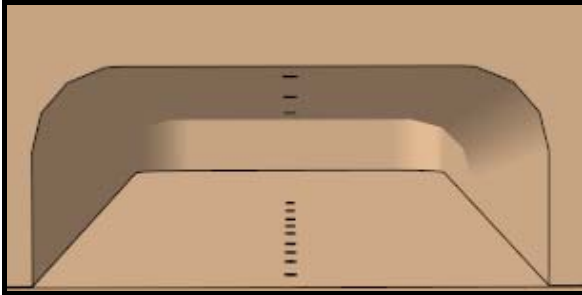

Figure 3: Test article nozzle detail with line matrix of temperature sensors.

The 2-D Nozzle is manufactured of copper and consists of two parts that are bolted together with twelve M5 bolts. Sealing is provided by an Indium gasket of 0.005 in. (0.13mm) thickness that cold-welds to the copper upper and lower parts of the nozzle. Exact measurement of the throat height is conducted after assembly, in order to take into account actual compression of the Indium gasket.

The nozzle is installed on the Mounting Structure. In between the Nozzle and Mounting Structure, sheets of High Molecular Poly Ethylene (HMPE) are installed to limit the thermal conductivity between the two components.

The *Swagelok SS-1210-1-12* connectors are manufactured of stainless steel. Sealing between connectors and copper nozzle is achieved by applying Teflon tape.

### Propellant

Among a wider preliminary selection, three potential candidates have been investigated in detail as working fluids:

- Methane (CH<sub>4</sub>),
- Ethane (C<sub>2</sub>H<sub>6</sub>),
- Ethylene (C<sub>2</sub>H<sub>4</sub>).

Other fluids have been discarded for one or several of the following reasons:

- Environmental impact (fluoroclorocarbons)
- Molecular stability and complexity (decafluorobutane.)
- Unsuitable thermodynamic behavior (FC-72)

In order to perform cold gas tests, the working fluid has to stay in suitable thermodynamic conditions all along the subsonic/supersonic expansion. Moreover the working fluid must have low heat capacity (in order to be easily sub cooled) allowing condensation at the nozzle wall.

Ethylene (C<sub>2</sub>H<sub>4</sub>) is the most promising fluid because:

- It is gaseous at ambient temperature and moderate pressure (up to 20 bar).
- It remains in gaseous phase at thermodynamic conditions induced by moderate supersonic expansion (M 1.5 – 2) Figure 4
- It condensates at relatively high temperature (150 K) when pressure decreases to the lowest acceptable limit (min pressure = 0.3 bar, in order to prevent flow separation).
- It can easily be sub-cooled (low C<sub>p</sub>).
- Ethylene is environmentally safe and not toxic.

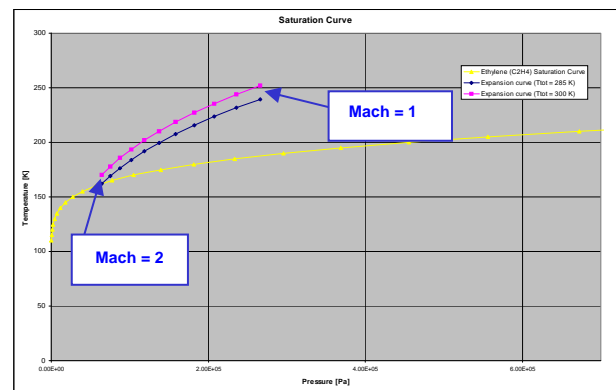

Figure 4: Comparison of ethylene saturation curve and thermodynamic status along the supersonic nozzle (1D computation)

## 4. COOLING CIRCUITS

Cooling is provided in three areas by 3 separate, but identical cooling circuits. Each cooling circuit consists of an inlet manifold, equipped with pressure and thermal sensors, 4 coolant tubes of 2 different internal diameters (4 mm and 2 mm) and one outlet manifold, again equipped with thermal and pressure sensors. The flow of the coolant, when it enters the in the 2-D nozzle embedded lines is in the same direction as the propellant flow that it is meant to cool. The coolant tubes can clearly be identified in red in Figure 2 and in Figure 5. Eccobond 56 C is used to provide proper thermal conduction between the 2 mm and 4 mm coolant lines and the lower part of the

nozzle, in which the cooling lines are embedded. Figure 6 shows a cross section of the 2-D nozzle and location of the three cooling circuits. The cooling circuits are manufactured of copper. Sealing between the two parts of the inlet and outlet manifolds is provided by an indium gasket. The parts are bolted together. The cooling circuits are mounted via brackets to the mounting structure. HMPE gaskets reduce the thermal leak from the mounting structure to cooling inlet and outlet manifolds. The inlet and outlet pipes are manufactured of *Swagelok 3/8 in.* stainless steel pipes that are hard-soldered with silver to the copper manifolds. Connectors are of the *Swagelok SS-600-6* type.

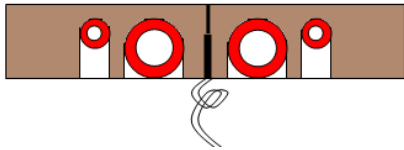

Figure 5: 2-D nozzle detail with embedded coolant tubes and temperature sensor

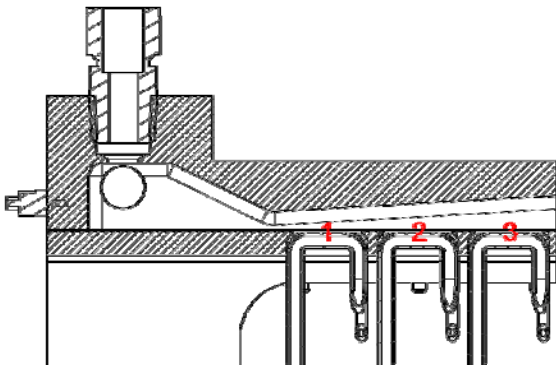

Figure 6: Cross section of 2-D nozzle with numbering of three independent cooling circuits

A simplified EcosimPro model (Figure 7) with indication of entry boundary conditions on the left, junction (for coupling components), pipework characteristics (such as diameter, number of bends, angle of bends etc.), working fluid indication (Nitrogen) and outlet boundary conditions, has been used to preliminary design the cooling circuits.

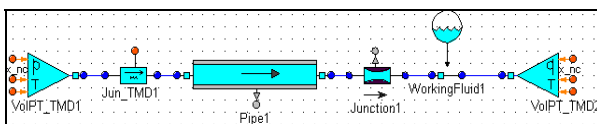

Figure 7: Hydraulic model of cooling tube

## Coolant

An obvious choice for the cooling liquid is Nitrogen. It is relatively cheap and safe to operate. The cooling circuit can be fed with either liquid or cold gaseous Nitrogen as long as phase change inside the cooling circuit is prevented. The coolant is provided at mass flow rates up to 0.15 kg/s in case of cold gaseous nitrogen and up to 0.075 kg/s in case of liquid nitrogen.

## 5. INSTRUMENTATION

The test article is equipped with pressure sensors, temperature sensors and low cost thermocouples.

### Pressure sensors

Two types of pressure sensors have been used for pressure measurement:

- Kulite XTL-190M-13.5BAR-A - Operational range: -55 to + 170 °C
- Kulite CT-190M-17BAR-A - Operational range: -195.5 to + 120 °C

The two different versions have been selected for cost reduction purposes. Where no cryogenic temperatures occur, smaller range sensors are applied. Pressure sensors are modelled as indicated in Figure 8. The various locations of the pressure sensors can be seen in figures Figure 1, Figure 2 and Figure 10.

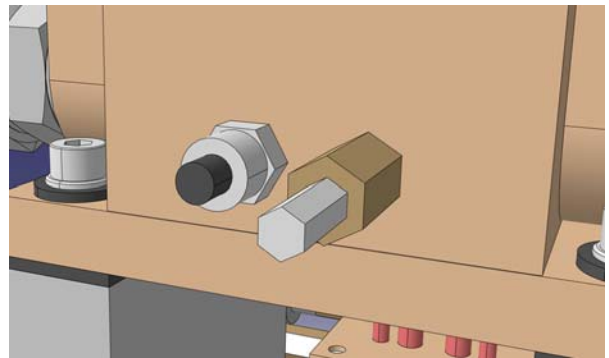

Figure 8: Pressure sensor (left) and temperature sensor (right)

### Temperature sensors

Two types of temperatures sensors are used for accurate temperature measurements.

- Medtherm coaxial Thermo element, Type TCS-031-T-0.25-0-TG17-B1SR-AA  
Operational range: -270° C to + 400° C
- Medtherm coaxial Thermo element, Type TCS-031-T-1.9-0-TG17-B1SR-AA-BAA  
Operational range: -270° C to + 400° C

Temperature sensors are modelled as indicated in Figure 8. In Figure 1, the locations of temperature and pressure sensors to measure conditions in the main feeding chamber are clearly visible. Figure 2 shows the temperature sensors on the inlet and outlet manifolds of the cooling circuits.

Figure 9 shows the location of temperature sensors and pressure sensors in the 2-D nozzle with respect to the throat.

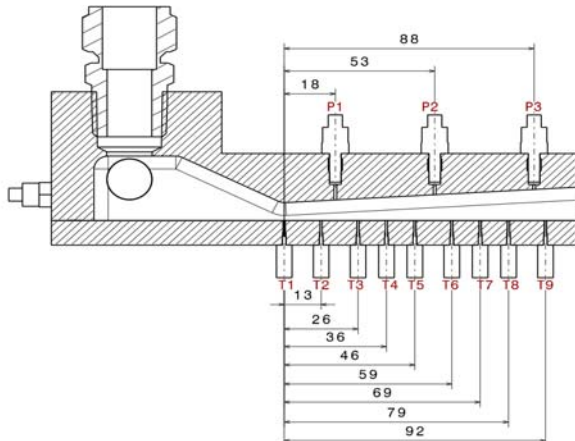

Figure 9: Indication of location of thermocouples and pressure sensors in the expanding nozzle area

#### **Additional temperature sensors**

About a dozen of simple and low cost thermocouples are added to various locations on the hardware for additional temperature verification.

#### **Optical measurements**

Video footage is generated during the test runs. This includes as well high speed camera footage, focusing on the condensation layer inside the 2-D nozzle as well as general recording of the complete test set up under test.

#### **Acquisition system**

Pressure sensor and temperature sensor readings, as well as readings from the additional thermocouples are recorded on a laptop. The laptop interfaces with the sensors via Keithley 2701 readout equipment connected to a 7708 board for the temperature sensors and a 7702 board for the pressure sensors. Multi Channel Process System v6.2 is used to record the data and to visualize measurements on screen.

## **6. MOUNTING STRUCTURE**

The Mounting Structure carries all the experimental and handling loads that may occur during experimental runs, handling and transport of the test article. The Mounting Structure is manufactured of aluminium and interfaces with the test bench via four M12 screws.

Dedicated brackets serve to support the cooling circuits and either strict tolerances on the pre-assembled items, or slotting of bolt provides the required margins for assembly. The mounting structure can be clearly identified in among others Figure 10.

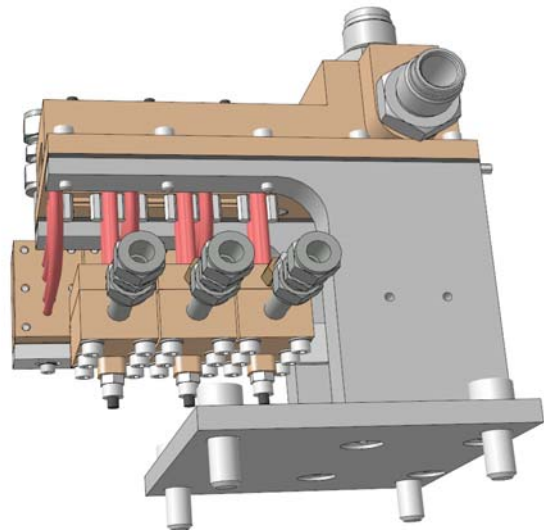

Figure 10: Low side view of test article with grey mounting structure clearly visible.

## **8. TEST CAMPAIGN**

A first set of tests has been carried out at TNO facilities in the Netherlands in February 2010.

Very precise and accurate temperature measurements have been acquired, providing accurate knowledge of the thermodynamic status of the Ethylene jet near the nozzle wall. Accuracy of thermocouples has been verified on the full measurement range prior to installation. Accuracy has been monitored all along the test campaign, resulting in a measurement scattering better than 1° C at the lowest temperatures (98 K).

Condensation/evaporation conditions have been observed and documented both by temperature and video recording.

Detailed analysis of the complete data set is ongoing.

Figure 11 shows the test article ready for testing on the test bench.

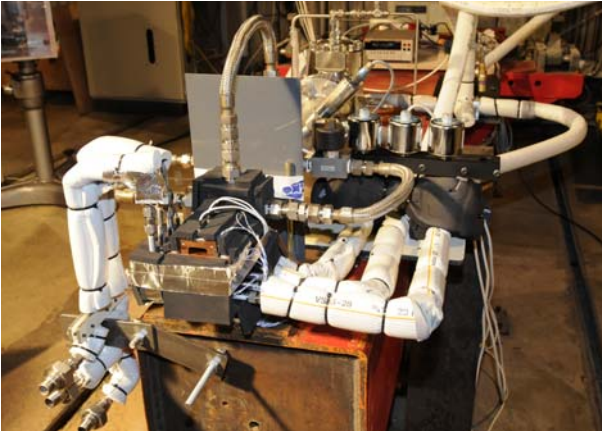

Figure 11: Test article ready for testing

Figure 12 shows the Ethylene exhausted plume during testing activities.

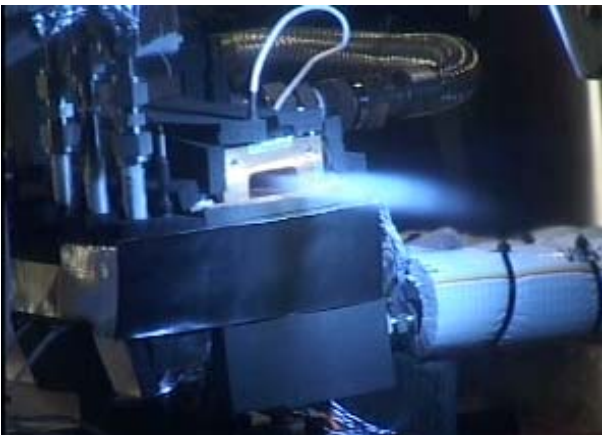

Figure 12: Ethylene exhaust plume during testing.

## 8. CONCLUSIONS

The Heat Transfer at Wall experimental test article has been developed and manufactured in a short time, at low cost and making use of ESTEC internal resources and technical expertise. The hardware has been assembled at ESTEC facilities and preliminary checked prior to start of the test campaign. Wall temperature measurements demonstrated very high accuracy and condensation / evaporation thermodynamic conditions have been reached several times during the test campaign.

Valuable experimental data has been gathered and has been stored in a database. Analyses of the data is on-going and a second test campaign, with similar test configuration, could be implemented in short time, in order to investigate the effect of premixed non-condensable gas on heat transfer and phase change phenomena.

## 9. REFERENCES

1. EcosimPro 4.6 Software Package
2. 12205/07/NL/CP ESPSS – Iss. 2 – EcosimPro Libraries User Manual, September 2009.
3. NIST database
4. REFPROP 7 Software package

## 10. ACKNOWLEDGEMENTS

This work has been funded by the Ariane 5 ME project. The authors especially would like to thank Mr. B. Lehmann of ESA for providing the readout equipment. The authors would also like to thank TNO personnel for their cooperation and continuous support.