

VEGA-AVUM-PLS model under EcosimPro Environment: Development and Validation

L. Boccaletto¹, M. Marchionni²

(1) ESA ESTEC, Propulsion Engineering Section, luca.boccaletto@esa.int

(2) ESA ESTEC, Propulsion Engineering Section, massimo.marchionni@esa.int

ABSTRACT

This paper presents the AVUM-LPS performance model developed under the EcosimPro environment in ESTEC at TEC-MPC (Chemical Propulsion Section). The model is intended as cross-check tool for ESA internal use to verify Industrial computations, test predictions and data reduction. The model had been developed on the basis of available technical data, taken from Industry technical documentation at its latest issue. Only nominal values had been taken into account therefore not considering tolerance analysis. When not available, geometrical and hydraulic parameters, in particular for the main engine, had been estimated (engineering judgement): as a general rule for validation purpose, only unknown (estimated) parameters had been tuned in order to calibrate the numerical model on the basis of experimental results. The model had been created in a "building blocks" approach: the physical system had been split in 4 main sub-assemblies, namely the Helium common Pressurization Control Assembly (PCA), the 2 Propellant Isolation Assemblies, one each for NTO and UDMH and the MEA engine. Each block can run separately (with appropriate boundary conditions) or be integrated along with other blocks to form "part of" or "the whole" LPS. The model had been validated on the basis of PVM tests (PCA and PIA's), QM test campaign (MEA model) and UC-FIRE slam start and firing campaigns. As a general requirement, maximum allowed errors had been kept lower than 3% at nominal operating conditions. A global check had been performed in order to verify all the other operating points (MEA operational and qualification boxes). The model is now available in its validated status and can be used to simulate ground tests and flight operations

INTRODUCTION

The LPS bi-prop propulsion subsystem delivers thrust to the VEGA Launcher Upper Composite, the AVUM (Attitude Vernier Upper Module). The Upper Stage thrust is provided by the 2.5 kN Main Engine Assy (MEA), manufactured by Yuzhnoye, fed by the PCA (Pressurant Control Assy) and the fuel and oxidizer PIA's (Propellant Isolation Assy) designed by AVIO. The propellants are UDMH (fuel) and NTO (oxidizer). The LPS schematic is depicted in figure 1.

The associated EcosimPro model is built up on 4 main sub-models:

- The Helium common pressurisation system (blue shading in figure 1) or PCA.
- The NTO feeding branch (red shading in figure 1) or NTO PIA.

- The UDMH feeding branch (green shading in figure 1) or UDMH PIA.

- The MEA engine (yellow shading in figure 1).

Each sub-model had been created using the EcosimPro 4.4.0 software, including the ESPSS libraries, version 1.1.c. All the model components had been taken from the available list of predefined schematics; only the heat flux splitter (MEA engine model) is a custom element. Figure 1 shows the actual LPS schematic and the 4 main sub-models perimeters, while Figure 2 illustrates the EcosimPro model.

The AVUM-LPS model described above has followed mainly independent development for each block, where the first validation loop had been carried out onto the MEA UDMH and NTO circuits. Hydraulic characteristics and channels geometry had been derived by the engine CDR datapackage while reference data for validation had been taken from the MEA QM1 test report. The same approach applies to the thrust chamber. The first MEA model was developed with libraries 1.1.a which had been subsequently upgraded to release 1.1.b. The model was then adapted and included in the LPS model for full validation with the release 1.1.c. Its derivation and validation is detailed in following chapter "MEA Block Development and Validation". The 3 blocks representing the PCA (1 block) and the PIA (1 block each propellant) had been developed from calibrated AVIO fluid-dynamic model used in the design phase to derive equipments specifications backwards from the MEA operating box. The validation process implied data from the PVM (Propulsion Verification Model, LPS representative hydraulic model w/o MEA) test campaign with simulant – demineralised water – instead of real propellants. This process allowed for a fine tuning of the unknown coefficients, mainly relevant to the Pressure Regulator. In fact, such component is supplied by an U.S. company therefore stringent ITAR rules and patents restrictions apply to design parameters. Further details as well as validation results are reported in following chapters "PCA Block Development", "NTO & UDMH PIA Blocks Development" and "LPS Development and First Loop Validation". This whole phase envisaged the ESPSS libraries version 1.1.b. Following the LPS UCFIRE campaign, where the PVM had been mated with the MEA adapted to sea level firing (shorten nozzle), and the MEA QM2 test results both the MEA and the overall models had been revised to improve the data fitting. Moreover, libraries upgrade to release 1.1.c was followed by a model update. Further details as well as validation results are reported in section "LPS Model Final Validation", while for

libraries acknowledgement ref [1] is recommended. In this way, also the extreme modularity followed by the authors in developing and validating the model is shown.

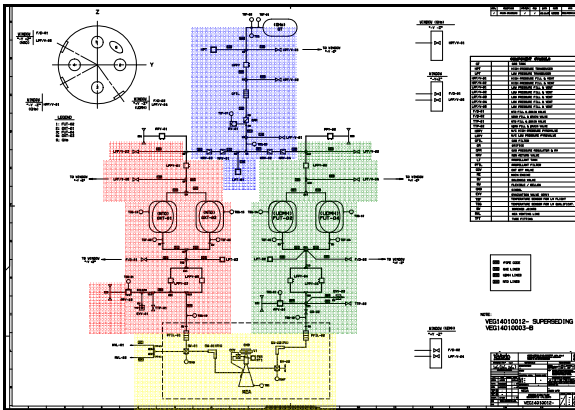

Figure 1: LPS schematic and blocks identification

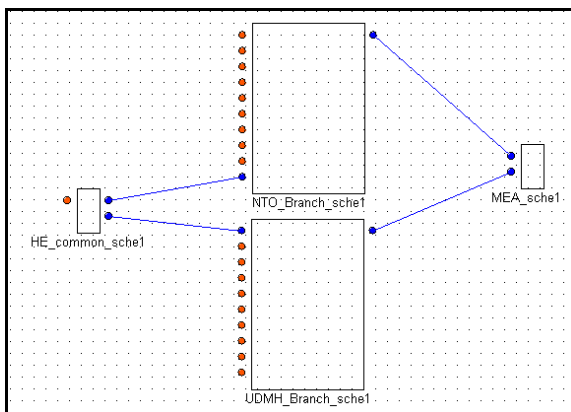

Figure 2: LPS EcosimPro Model

MEA Block Development and Validation

The MEA model simulates the functional behaviour of all the engine components, including calibrating orifices, pipes, solenoid valves, filters, cut-off valve, regenerative circuits, combustion chamber and nozzle. The global heat flux coming from the combustion chamber (including the first part of the nozzle) is split in 2 heat fluxes, according to the actual chamber geometrical definition, in order to reproduce the physical behaviour of the two parts of the UDMH regenerative circuit.

Technical characteristics of main components, as well as details of engine inner geometry, had been taken from LPS and engine technical documentation (see note in the reference section). One major deviation between the actual MEA configuration and the model exists. The available EcosimPro chamber model doesn't allow representing film cooling injections. Consequently, the following

approaches had been adopted for the NTO and UDMH film injections:

- **NTO film cooling:** the entire NTO mass flow rate is directly injected into the combustion chamber through the injector head. This assumption implies that the effective injector cross section area, as well as the associated pressure loss coefficient, had been adapted to obtain the correct global pressure drop along the NTO line. Moreover, the heat exchange coefficient at regenerative circuit level had been tuned in order to obtain the correct temperature level (equivalent thermal shielding of film cooling).
- **UDMH film cooling:** similarly to the NTO strategy, the complete mass flow rate is injected into the combustion chamber through the injection head adapting the equivalent cross injection area, the pressure drop coefficient and the heat exchange coefficient. Nevertheless, according to the actual engine configuration, the UDMH flow rate entering the second part of the regenerative circuit (cylindrical part of the combustion chamber) had been properly represented in the model. Indeed, part of the UDMH flow rate is by-passed at the outlet of the first part of the regenerative circuit (throat area). Two orifices had been included at the end of the two circuit branches, simulating the injection losses at injection head and at film cooling slot, respectively. This allows having the proper pressure loss and propellant heating in both end bifurcations of the UDMH circuit prior to injection into combustion chamber. It should be noted that the pressure loss at CC component level is set to zero, as the two calibrating orifices are already taking into account the injection losses.

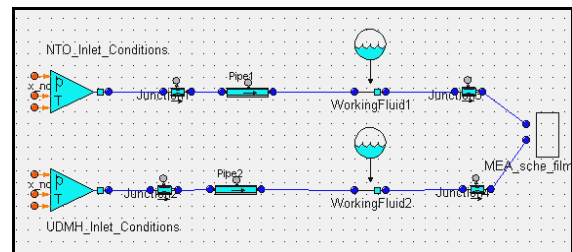

Figure 3: EcosimPro Model for MEA validation

MEA model had been validated in a two steps approach. The first step allowed validating each hydraulic circuit (NTO and UDMH) in terms of pressure losses through each component (valves, filters, orifices, ...), as well as the thrust chamber in terms of mass flow rates, injection pressure losses, combustion pressure and thrust. The second step was intended to validate the complete MEA engine model, taking into account all the internal thermo hydraulic

couplings. Parameters already validated in the first step had been kept constant. The EcosimPro model used for this second step is reported in figure 3. In the following paragraphs, detail of each single validation step is provided. Experimental results of the QM2 engine test n. 677 – operating point “A” – had been used as a reference experimental database.

THE FEEDING SYSTEM

Helium PCA Block Development

The Helium gas piping model had been validated on the basis of experimental results collected during the “Buid 1” expulsion test campaign. The tested configuration is in accordance with the PVM “Build 1” (no pyrovalves and dummy tanks) configuration whereas the associated model (only gas piping) is given in figure 4. Helium mass flow rate had been imposed as a boundary condition (for each propellant circuit), and computed pressure drops had been compared to experimentally measured values. The model had been calibrated adjusting two parameters:

- Piping roughness (set at nominal value – 5 µm);
- NRV pressure drop coefficient.

Obtained results are in good agreement with experimental data. On the basis of these results, all the parameters of the Helium piping model had been frozen until UC-FIRE results were made available.

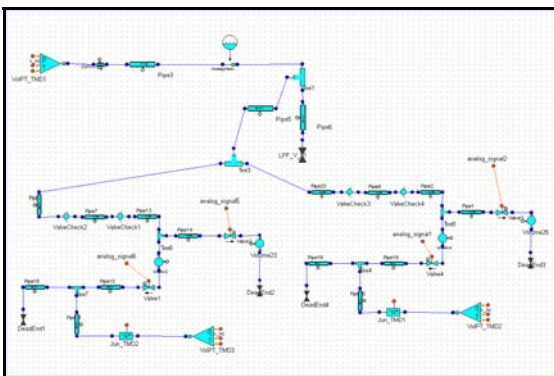

Figure 4: The PCA model for validation

NTO PIA Block development

The NTO feeding branch is the LPS part comprised between the outlet of non return valve NRV-03 (I/F with the Helium common pressurisation system model) and the NTO inlet point of the MEA engine (I/F with the MEA engine model) – figure 5

Technical characteristics of main components had been taken from available technical documentation of LPS. Pipes have also been defined according to LPS technical documentation and drawing. Moreover, loss coefficients for T-joints had been defined according to relevant chapters of ref. [2].

The NTO liquid piping model had been validated on the basis of the PVM characterisation tests. Water mass flow rate had been imposed as a boundary condition, and computed pressure drops had been compared to experimentally measured values, results are presented in table 1, where the mass flow rate refers to water flow.

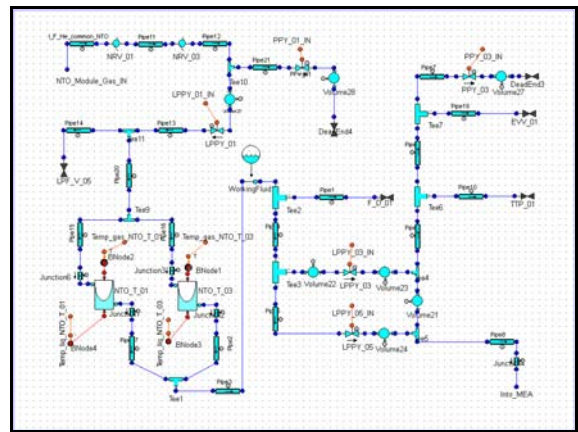

Figure 5: The NTO PIA model

The model had been calibrated adjusting two parameters:

- Piping roughness
- Pyrotechnic valves loss coefficient

Mass Flow (Kg/s)	Discrepancy (%)
0.45	~3.15
0.35	~1.63
2.68	~2.2

Table 1: NTO line pressure drop comparison, PT 11-19 t

On the basis of validation results, all the parameters of the NTO piping model had been frozen until UC-FIRE results were made available. Two pressure transducers pairs were available in order to validate the NTO liquid piping model:

- Pressure transducers PT-11t and PT-19t, positioned at NTO T_01 tank outlet and just before the MEA I/F, respectively.
- Pressure transducers LPT-03 and PT-13s, positioned upstream and downstream the pyro-valves, respectively.

UDMH PIA Block Development

The UDMH feeding branch is the LPS part comprised between the outlet of non return valve NRV-04 (I/F with the Helium common pressurisation system model) and the UDMH inlet point of the MEA engine (I/F with the MEA engine model) – figure 6. Technical characteristics of main components had been taken from available technical documentation of LPS. Pipes have also been defined

according to LPS technical documentation and drawing. Moreover, loss coefficients for T-joints had been defined according to relevant chapters of ref. [2].

The UDMH liquid piping model had been validated on the basis of the PVM characterisation tests. Water mass flow rate had been imposed as a boundary condition, and computed pressure drops had been compared to experimentally measured values.

The model had been calibrated adjusting two parameters:

- Piping roughness
- UDMH calibrating orifice

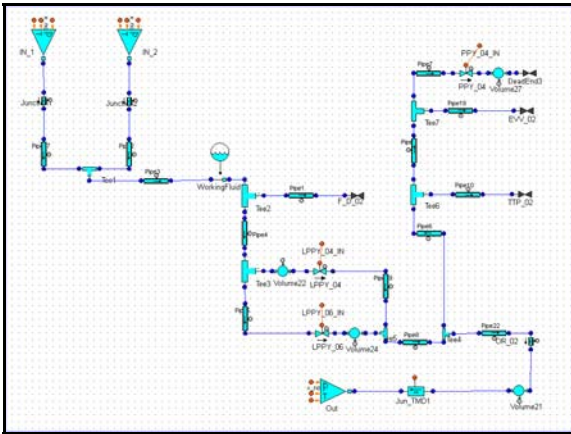

Figure 6: The UDMH PIA model

Mass Flow (Kg/s)	Discrepancy (%)
0.36	~2.96
0.322	~1.06
0.252	~4.65

Table 2: UDMH line pressure drop comparison with PT 10-20 t

Mass Flow (Kg/s)	Discrepancy (%)
0.36	~2.74
0.322	~1.49
0.252	~10.66

Table 3: UDMH gas line pressure drop comparison with PT 12-20 t

Mass Flow (Kg/s)	Discrepancy (%)
0.36	~1.29
0.322	~1.56
0.252	~2.05

Table 4: UDMH gas line pressure drop comparison with PT 12-18 t

Pyrotechnic valves loss coefficient had been set equal to the value used for the NTO liquid piping model, this value being frozen after validation of NTO branch. Obtained results are displayed in above tables 2, 3 and 4 for the lines, where the mass flow rate refers to water flow. Part of the discrepancy observed at low mass flow rates is also related to the measurement scattering (in particular transducer PT-20t).

Four pressure transducers pairs were available in order to validate the UDMH liquid piping model:

- Pressure transducers PT-10t and PT-20t, positioned at UDMH T_02 tank outlet and just before the MEA I/F, respectively.
- Pressure transducers PT-12t and PT-20t, positioned at UDMH T_04 tank outlet and just before the MEA I/F, respectively.
- Pressure transducers PT-12t and PT-18t, positioned at UDMH T_04 tank outlet and just downstream the pyrovalves section, respectively
- Differential pressure transducer PTD-02, measuring pressure drop between the pyrovalves section and (downstream) the calibrating orifice.

Pressure transducers PT-12t and PT-18t probably give the most reliable pressure drop measurement, because their location (PT-18t is upstream the calibrating orifice) and consequently the absence of pressure fluctuations induced by the turbulence generated at orifice level. Pressure transducer PT-20t is less affected by turbulence generated at orifice level. Therefore, PT-10t / PT-20t and PT-12t / PT-20t are chosen for validation purposes.

For these three couples of transducers, numerical results are in good accordance with experimental data. The small pressure unbalance (between UDMH Tanks #2 and #4) experimentally found at very low mass flow rate, is not reproduced by the numerical model. On the basis of these results, all the parameters of the UDMH piping model had been frozen until UC-FIRE results were made available.

THE LPS MODEL DEVELOPMENT AND FIRST VALIDATION LOOP

Each sub-model of the AVUM LPS above described had been embedded in an EcosimPro "block", with communications ports, allowing interfacing and communication between connected elements and circuits (exchange of transport properties and thermodynamic variables). In this way, it had been possible to create the complete LPS performance model, using each single sub-model as a building block. Initial and boundary conditions are declared in a dedicated input file. Simulation results can be displayed in an EcosimPro related environment and can be saved in text file. Computations are always unsteady: transient behaviour can be

Executive Secretariat
6 Rue Galilée
75016 PARIS
Phone : 33 (0) 1 56 64 12 30
Fax : 33 (0) 1 56 64 12 31
E-mail : secr.exec@aaaf.asso.fr

computed; otherwise, restart from a previously computed operating status is also possible.

The final verification of the VEGA AVUM LPS model had been carried out assembling all the previously validated sub-models (excluding the MEA engine model) and simulating expulsion tests performed on the Build 1 and Build 2 PVM configurations. Main difference in the 2 builds: The PVM Build 1 had no pyrovalves and dummy tanks. During these tests, needle valves were installed on the NTO and UDMH feeding lines, just upstream the MEA I/F points to simulate solenoid valves call for flow. Measured mass flow rate had been imposed as boundary condition at the end of each feeding line of the model. The model verification had been performed on the basis of comparison between measured and computed pressure losses.

This verification differs from the previously described validation activities because the presence of bladder tanks and because the complete coupling of all the gas and liquid piping and equipments.

Simulations had been performed imposing boundary conditions allowing mass flow rate similitude (as far as possible, depending on available experimental data) with actual propellant. This choice is justified by the fact that main pressure losses are concentrated on valves and other equipments; distributed pressure losses (for which Reynolds number can have an effect) represents a minor contribution to the global pressure loss.

THE LPS FINAL VALIDATION

This section presents the first simulation results obtained by making use of the AVUM-LPS performance model, previously developed under the EcosimPro environment as described herebefore.

The complete LPS model is used and two types of simulations are performed:

- UC-FIRE Slam Start
- UC-FIRE Hot Firing Test

Also a complete "Slam-Start & Firing Test" simulation is performed, in order to check the model robustness for long and complex simulations. Main objectives of these preliminary computations are the following:

- To improve the model validation degree
- To check the model behaviour during following transient phases:
 - Slam start.
 - MEA start-up.
 - MEA shut-down (water hammer)

Experimental data are available from UC-FIRE test campaign. Comparison between numerical results and experimental values had been performed. For what concerns engine ignition tests the

following two aspects shall be taken into account while reviewing the comparisons:

- Regulated operational point is not always achieved because the short duration of the tests, comparatively to the time needed for the pressure decay from lock-up to regulated values.
- MEA thermal steady state not achieved.

The longer firing tests (engine and LPS steady state operating mode) allowed for a tuning of the model in the shorten MEA nozzle configuration (so called "sea-level" tests).

UC-FIRE Slam Start

UC-FIRE slam start and subsequent tanks pressurisation phases had been simulated in order to investigate the propagation of the pressure wave downstream the Gas Pressure Regulator (GPR) when the High Pressure Pyrotechnic Valve (HPPY) is fired.

The assumed initial conditions are the following:

- Initial pressure in Helium Gas Tank: 310 bar.
- Initial pressure in the Helium piping, between the HPPY and isolation valves (LPPY_01 and LPPY_02 on NTO and UDMH branches, respectively): near vacuum.
- Initial pressure in the Helium piping, between the LPPYs and propellant tanks:
 - NTO side: 0.8 bar.
 - UDMH branch: 0.35 bar.
- Initial temperature (H/W and fluids): 293 K.
- LPPY_01 and LPPY_02 are opened at the beginning of simulation (H0+0.001s) allowing stabilisation of pressure conditions in the Helium piping, in particular in correspondence of junctions between sub-models.
- The HPPY valve is opened 1s after simulation starts.

It has to be taken into account that the Relief Valve is not simulated in this model. Comparing test results with the model plots, minor mismatch appears to exist between predictions and measurement for what concerns pressurization curves. This is mainly associated to poor modelling of the gas pressure regulator (US component, under ITAR regulation). Indeed, deficiencies associated to such component are severe as per hereafter list:

- The influence of inlet pressure on regulator valve opening is not included.
- Sonic and supersonic conditions through the regulator's orifices and internal passages, as well as pressure losses due to shocks can not be exactly reproduced in the EcosimPro model. Consequently, dynamic and transient behaviour of this component is badly simulated.

- Non-linearities associated to Belleville spring are not taken into account.

As a consequence of above, the authors of the present report aimed to fit test results slope in the interval between 10 to 15 seconds with predictions within 5 to 10 seconds. In fact, in such a way the observed plateau is not considered as the model manifestly cannot reproduce this behaviour. This setting ensures to reproduce the pressure drop along the lines. This is more relevant to quasi steady state simulations, which had been used previously to develop the model, see previous paragraph. Therefore for what concerns the pressurization time, large discrepancy is observed.

Main results are the following:

- Lock-up pressure (34.2 barg) inside NTO tanks is obtained in less than 25 s.
- Lock-up pressure (34.2 barg) inside UDMH tanks is obtained in less than 30 s.

The difference between the NTO and UDMH pressurization time is consistent with the difference in ullage volume (bigger for UDMH) and the different vapor pressure between the two propellants.

UC-FIRE tests 1BR, 2 and 3 B

To predict firing tests performed with coupled LPS feeding lines and MEA, model described in previous chapter was used. It is worth to recall that in atmospheric conditions and without the vacuum chamber adapter installed, FSS – Free Shock Separation – regime exists inside the engine nozzle. Consequently, at the nozzle lips the extension walls are not touched by the exhaust plume. Moreover, cold air coming from the surroundings cools down the radiative part of the nozzle extension thus keeping low the temperature of both nozzle walls and propellant in the NTO regenerative circuit. This impacts NTO viscosity and therefore the regenerative circuit pressure drop, expected to be higher than in nominal conditions, i.e. vacuum. To cope with such aspect, the wall – exhaust heat exchange coefficient had been drastically reduced to be negligible. In particular, the NTO regenerative circuit conductivity had been reduced by a factor of 10^{-2} . An additional tuning of the MEA model had been carried out after first validation achieved as previously presented in this paper. Such calibration had been obtained through the MEA test model as per figure 7, where UC-FIRE test 2 & 3 B inlet pressures had been used as inputs. It shall be reminded that the MEA QM 1 & 2 models were used for initial model development while the UCFIRE test article mounts the DM2 engine model. Therefore, the calibration orifices were modified at first and then heat exchange tuning was performed as explained.

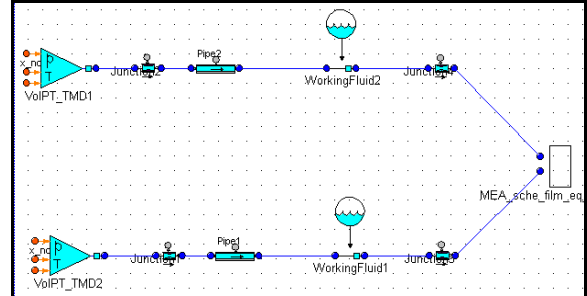

Figure 7: EcosimPro model for MEA DM engine block validation

After fine tuning of the MEA model, the complete LPS model had been used to simulate a long firing test. The main test selected for comparison is 1BR, 50 second ambient firing at the nominal point. It is worth to mention that actual tanks filling level must be taken into account at the beginning of simulation, in order to correctly reproduce the evolution of the engine feeding pressure, from lock-up to regulated level. Indeed, filling levels have a large impact as they drive the time constants of tank – and therefore at MEA inlets – pressures linked to the actual ullage volumes. Before test 1BR two tests of 5 respectively 15 seconds were run, therefore loading figures need to be re-computed starting from known propellant masses, loaded at the beginning of the test series. This is achieved by running 20 s of simulation to estimate propellant consumption. To take into account additional propellant masses expelled during shut-down transient – not fully representative of flight sequence, UDMH mass flow rate at NTO valve closing is approximated as follows:

$$\Delta p_{nom} = \frac{1}{2} \zeta \frac{Q_{nom}^2}{\rho}$$

$$\Delta p_{SD} = \frac{1}{2} \zeta \frac{Q_{SD}^2}{\rho}$$

From the ratio of above expressions the shut-down flow-rate is obtained:

$$Q_{SD}^2 = \frac{\Delta p_{SD}}{\Delta p_{nom}} Q_{nom}^2 \approx \sqrt{3} Q_{nom}^2$$

It had been though decided to verify the model at first on tests 2 & 3 B being these tests w/o LPS PCA resulting in faster simulations. For these tests, filling levels are not important as bench regulators have regulated and lock-up pressures very close excluding any significant contribution on pressure profiles associated to ullage volumes. Results are presented in tables 5 and 6. To explain such comparison figures, the considered pressures are here below recalled:

- PmO and PmF, are the pressures measured at the entrance of the Oxidizer and Fuel regenerative circuits respectively
- POI and PFI are the pressures measured at the injector dome of the Oxidizer and Fuel circuits respectively.

- The differences between PmO and POI and between PmF and PFI give the pressure drops along the Oxidizer and Fuel regenerative circuits respectively. These values are used to calibrate the model for what concerns the heat exchange, which in turn affect the propellants viscosity as mentioned before.
- PT-19t and -20t, are the pressures measured at the engine Oxidizer and Fuel respectively inlets.

The test 1BR, repetition of test at nominal point – “A”, is crucial for the LPS model tuning and verification. Indeed, it is the only test point where the LPC PCA, including regulator and check valves, is used to feed the MEA. As it can be seen from table 11, the model well predicts the main pressures in the system being the error below 1.5 %. The actual values had been taken from LPS technical documentation. The model is validated mainly with steady-state results; nevertheless the results presented in this section are encouraging for further model development.

Parameter (bar)	Discrepancy (%)
PmO	~0.5
PmF	~1.32
POI	~0.08
PFI	~1.375
Pcc	~0.9
PT-19t	~0.06
PT-20t	~0.03

Table 5: Test 2B comparison with MEA model

Parameter (bar)	Discrepancy (%)
PmO	~0.5
PmF	~1.32
POI	~0.08
PFI	~1.375
Pcc	~0.9
PT-19t	~0.06
PT-20t	~0.03

Table 6: Test 3B comparison with MEA model

A detailed comparison of pressure drops at MEA inlets due to fast SV's opening is deemed not significant being the main purpose of the present model to simulate steady state mode, nevertheless it is verified to be reproduced by the model implying a correct implementation of water-hammer physics. The results presented

allow for simulation of slow transients / quasi-steady time evolution, which was an object of the model definition / verification.

Parameter (bar)	Discrepancy (%)
PmO	~0.5
PmF	~1.32
POI	~0.08
PFI	~1.375
Pcc	~0.9
PT-19t	~0.06
PT-20t	~0.03

Table 7: Test 1BR comparison with MEA model

CONCLUSIONS

An AVUM-LPS performance model had been developed under EcosimPro environment, in the frame of the TEC-MPC support activities to IPT team, for the VEGA launcher. The model is intended as a cross-check tool for ESA internal use and to verify industrial computations, test predictions and experimental data analysis.

The model had been developed on the basis of available technical data, taken from industrial technical documents at their latest issue. Only nominal values had been taken into account.

The model had been created in a “building blocks” approach in order to simulate “part of” or “the whole” LPS system.

The model had been validated on the basis of PVM tests (Helium and liquid piping), QM engine test campaigns (MEA model) and UCFIRE test campaign. On the basis of these validation activities, the maximum computational error w.r.t. experimental data is lower than 3%.

The model, now available in its validated status, represents an operational tool allowing prediction of ground tests and flight LPS operational behaviour.

This model can also provide a first assessment on flight performances of VEGA AVUM Liquid Propulsion System, including the re-ignition capability.

Transient simulations (Slam start, MEA start-up and shut down phases) are also possible, even if MEA start-up and shut down transients are computationally expensive.

In all the performed simulations, all the dynamic pressure fluctuations generated by sudden events (valves' opening, MEA ignition, valves' closing, ...) were properly dumped, confirming that not sign of LPS instability could be detected.



Executive Secretariat
6 Rue Galilée
75016 PARIS
Phone : 33 (0) 1 56 64 12 30
Fax : 33 (0) 1 56 64 12 31
E-mail : secr.exec@aaaf.asso.fr

REFERENCES

[1] "ESPSS User Manual", version 1.4.1, Empresarios Agrupados, 2007.

[2] "Handbook of hydraulic resistance", Idelchik, I.E., 3rd ed. Begell House, 1994.

All the other relevant information reported in the present paper are taken from industrial documentation which cannot be disclosed, for further details please contact L. Boccaletto at luca.boccaletto@esa.int