

Overview of European Applications of EcosimPro to ECLSS, CELSS, and ATCS

Ramón Pérez-Vara

Empresarios Agrupados, Madrid, Spain

Sergio Mannu

Alenia Spazio S.p.A., Torino, Italy

Olivier Pin

ESA/ESTEC Thermal and Structures Division, Noordwijk, The Netherlands

Roland Müller

Astrium GmbH, Friedrichshafen, Germany

Copyright © 2003 SAE International

ABSTRACT

EcosimPro is the European Space Agency (ESA) standard tool to support Environmental Control and Life Support Systems (ECLSS or ECLS) analysis.

Processes used in ECLSS are multiple: fluid flow, heat transfer, chemical reactions, electro-chemical, biological, etc. As a result, EcosimPro is designed as a multi-disciplinary and flexible tool that can be easily adapted to simulate very different kinds of processes and systems.

There is a standard library of EcosimPro, which is mainly adapted to model air loops of conventional ECLSS. Some extensions to this library have been implemented to perform detailed fluid flow analysis which are beyond the scope of the traditional fluid flow solvers available in Thermal Analysis software.

The standard ECLSS library is well adapted to the thermo-hydraulic analysis of air cabin loops, but CELSS (Controlled Ecological Life Support System) and ATCS (Active Thermal Control System) have also been modeled by developing specific libraries of components.

EcosimPro has been used for the last 7 years as a standard ECLS tool for European space projects. Its range of application is rapidly expanding and it is the objective with this paper to present both an overview of the current applications of EcosimPro to ECLSS plus the emerging applications in the area of CELSS, ATCS and detailed fluid flow analysis.

INTRODUCTION

EcosimPro (formally Ecosim) is a generic simulation tool developed within an ESA supported activity since 1989. The development was driven initially by requirements to perform multi-disciplinary ECLS. The way to address the requirement for multi-disciplinary simulation capability was to design EcosimPro as a generic simulator that could be easily adapted to model different kinds of systems by creating libraries of simulation components.

The kernel of EcosimPro consists of a Differential/Algebraic Equation solver and a simulation language processor to translate an abstract definition of the model building blocks into a mathematical model, which can be solved in a computer.

Using the simulation language, the user is enabled to define different libraries of model building blocks (components in the EcosimPro terminology) for different disciplines. A standard library of ECLSS components is provided with the tool.

This paper describes the use of the tool by presenting current European applications of EcosimPro to ECLSS, CELSS and ATCS. The specific applications include:

- cabin air loops, which make use of the standard library of ECLSS components;
- special case fluid flow problems (venting lines and pressure regulators);
- CELSS (Melissa project), which has required a new library;

- ATCS applications, specifically the analysis of the Refrigerator Freezer Rack of the International Space Station (ISS).

ECOSIMPRO APPLICATIONS TO CABIN AIR LOOPS

The main purpose for which the standard ECLSS library of EcosimPro has been designed is the simulation of Air Management Systems. This library is capable of simulating the thermal-hydraulic behavior of cabin loops [3], and it is also capable of calculating the chemical composition of the cabin atmosphere.

Until now two air cabin loops have been analyzed using the standard ECLSS library: the Multi Purpose Logistic Module (MPLM) Cabin Loop [1], and the Attached Pressurized Module (APM) Cabin Loop [2].

ANALYSIS OF THE MPLM CABIN LOOP

The Multi Purpose Logistic Module (MPLM) is a kind of ferry for the transport of experiment racks and support equipment from Earth to the International Space Station

(ISS) and back.

The main function of the MPLM cabin loop is the ventilation of the habitable area in order to provide a comfortable air environment. The temperature and humidity control (THC) is supported by the Space Station via an Inter Module Ventilation Interface

Hydraulic analyses of MPLM cabin loop were performed using EcosimPro. The objectives were the fixation of the design of the cabin loop ducting with different elements, the layout and presetting of adjustable devices and the identification of critical points.

Figure 1 shows the flow sheet of the EcosimPro model of the MPLM cabin loop.

The MPLM model was successfully used for the purposes mentioned here above, and it enabled the prediction of the thermal-hydraulic behavior of the cabin loop. Detailed simulation results are reported in [1].

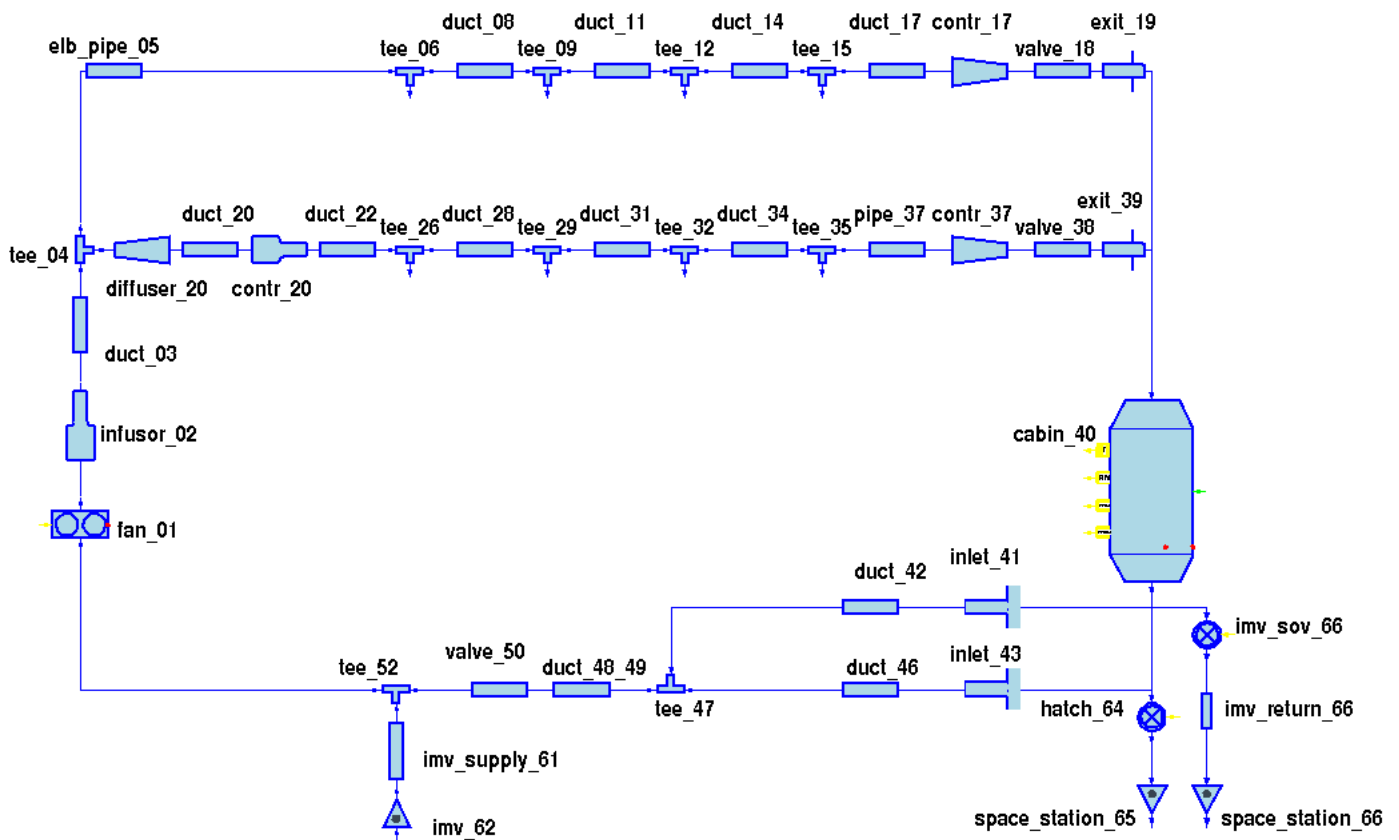

Figure 1 – EcosimPro Model of the MPLM air cabin loop

ANALYSIS OF THE APM CABIN LOOP

The APM is one of the major elements of the Columbus Orbital Facility (COF) programme, which represents the European contribution to the ISS. The APM is designed for multi-disciplinary payload missions such as micro-gravity, life science, earth observation, space science and technology disciplines. The APM Environment Control and Life Support Subsystem (ECLSS) provides a pressurized environment during module transportation to orbit and for on-orbit operation when docked to the Space Station with related crew operations.

The APM cabin loop is part of the ECLSS, and it provides the following main functions:

- a) Collection of heat loads from crew and radiative and convective heat loads from surrounding surfaces. Transfer of loads to the Thermal Control Subsystem (TCS) via the cabin air loop condensing heat exchanger (CHX)
- b) Collection of humidity produced by the crew and potential water leakage to the cabin from the CHX

- c) Ventilation of the habitable area with revitalization being achieved via IMV (Inter Module Ventilation)

The APM cabin loop was modeled using the standard ECLS Library of EcosimPro, and the final model is shown in figure 2. The main difference from the MPLM loop is that the APM loop provides Temperature and Humidity Control.

The objectives of the simulations performed with this model were:

1. Tuning of the controller of the bypass of the CHEX to minimize the number of displacements of the control valves while maintaining adequate control of the temperature and humidity
2. Determination of steady state performance of the system under different conditions.
3. The transitions between the different operating modes of the APM to check that the ECLSS is able to maintain the required environment in the APM cabin.

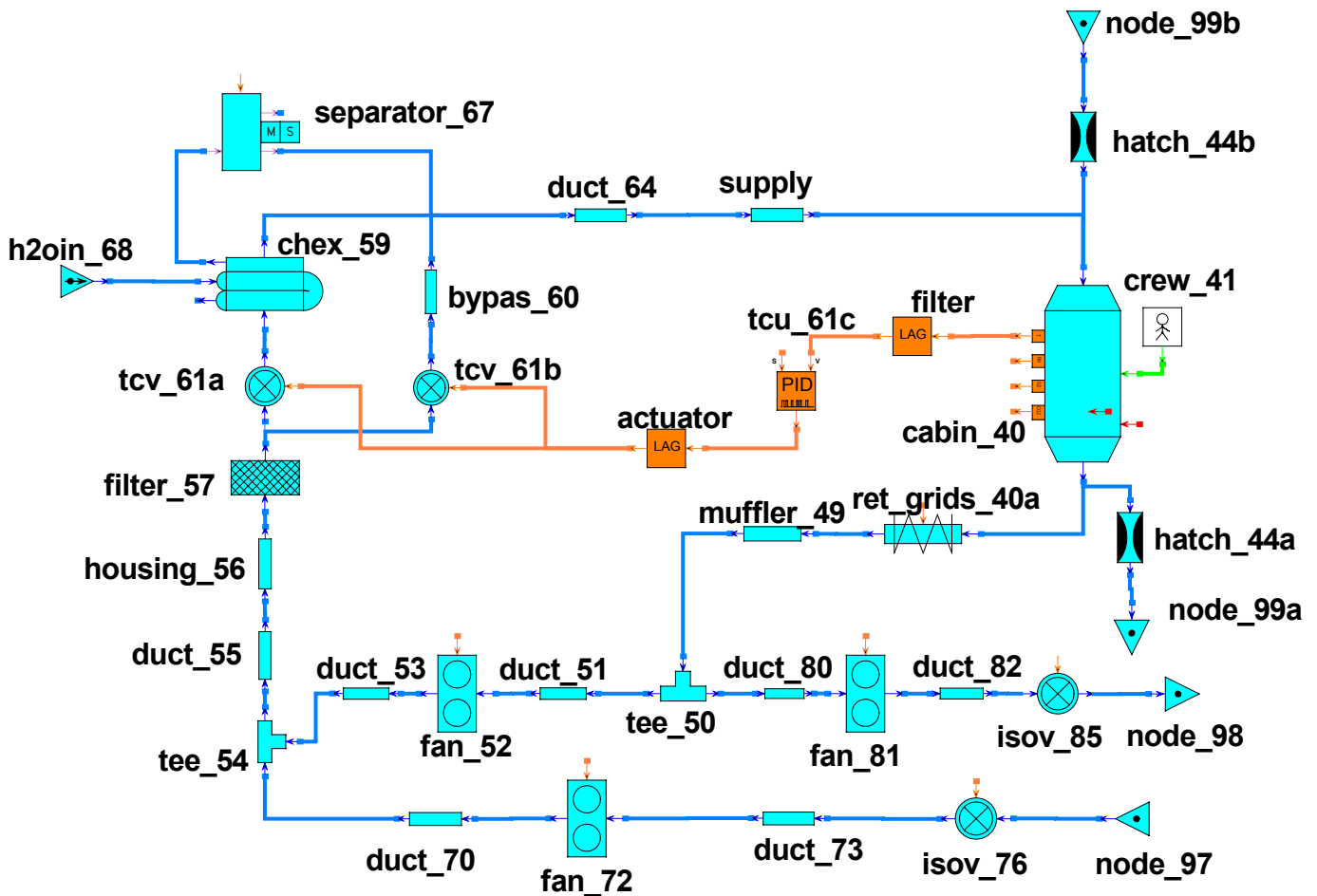

Figure 2 – EcosimPro Model of the APM cabin loop

All the above objectives were achieved with the model. The model correlated well with the hydraulic and temperature control tests performed on the APM cabin loop. Results for the transitions between the different operating modes have been reported in [2].

ECOSIMPRO APPLICATIONS TO DETAILED FLUID FLOW ANALYSIS

The fluid flow analyzers available in Thermal Analyzers were designed to represent spacecraft cooling loops.

Usually power in a spacecraft is a rather scarce resource, and cooling loops have to be designed for minimum energy usage. This implies low pressure losses and low coolant velocities. Consequently, the typical flow analyzers do not represent properly high-speed flows, choked flow and control loops.

There are cases like the design of venting lines to vacuum or the design of pressure regulators, where the limitations of the current flow analyzers are not acceptable.

The standard ECLSS library was designed with similar limitations, i.e. low pressure losses are assumed in the components, but EcosimPro is a very flexible tool and it is possible to overcome the current limitations by designing new components whose formulation does consider a wider range of phenomena.

ANALYSIS OF VENTING LINES

European space industries have been confronted with the design of several venting lines for Node 3 of the ISS. More specifically, the following three venting lines have had to be analyzed:

- Venting line of the hydrogen produced by electrolysis inside the Oxygen Generation Assembly (OGA), part of the Node 3 Oxygen Generation System (OGS) rack.
- Venting line of the carbon dioxide produced in the Carbon Dioxide Reduction Assembly (CDRA), part of the Node 3 ARS rack.
- Venting line of the methane produced by the Sabatier Reactor, part of the Node 3 OGS rack.

The phenomena that make venting lines difficult to analyze are listed here below:

- Compressible flow (high Mach number)
- Choked flow at several places, like valves, area changes and exits.
- Condensation of water vapor
- Solidification of water vapor

The objectives of the simulation of a line venting to the vacuum are:

1. Determination of fluid pressure, temperature and speed profiles along the line
2. Determination of the maximum thrust at the venting line outlet
3. Determination of the need to implement heaters along the venting device
4. Sizing of the heaters when they are needed

The way to face the problem has been to develop a new component of the ECLSS library, named PipeCompre. This is a pipe whose formulation takes into account all the above phenomena. Using this component, all the above analysis can be conveniently carried out.

Figure 3 represents an EcosimPro fluid flow model of a typical venting line. The venting line models also include a thermal network that connects the outer side of the pipe to the spacecraft walls and to the space. Thermal networks are usually entered using the EcosimPro Language instead of using the Graphical model editor, being possible to connect graphical and non graphical components.

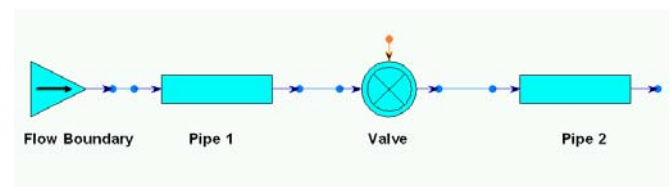

Figure 3 - EcosimPro model of a venting line

ANALYSIS OF PRESSURE REGULATORS

Analysis of pressure regulators is also a difficult problem, because it is necessary to take into account the non-perfect behavior of the gases at the typical storage pressures. Compressible flow and choking can also occur.

The Oxygen/Nitrogen delivery to the ATV Cabin is an example that was analyzed for the following purposes:

- Verification that ATV GDS is able to provide a gas flow rate within the range imposed by the design requirements, i.e. $1.3 \div 2.3 \text{ g/s @ } p = 1 \text{ bar}$

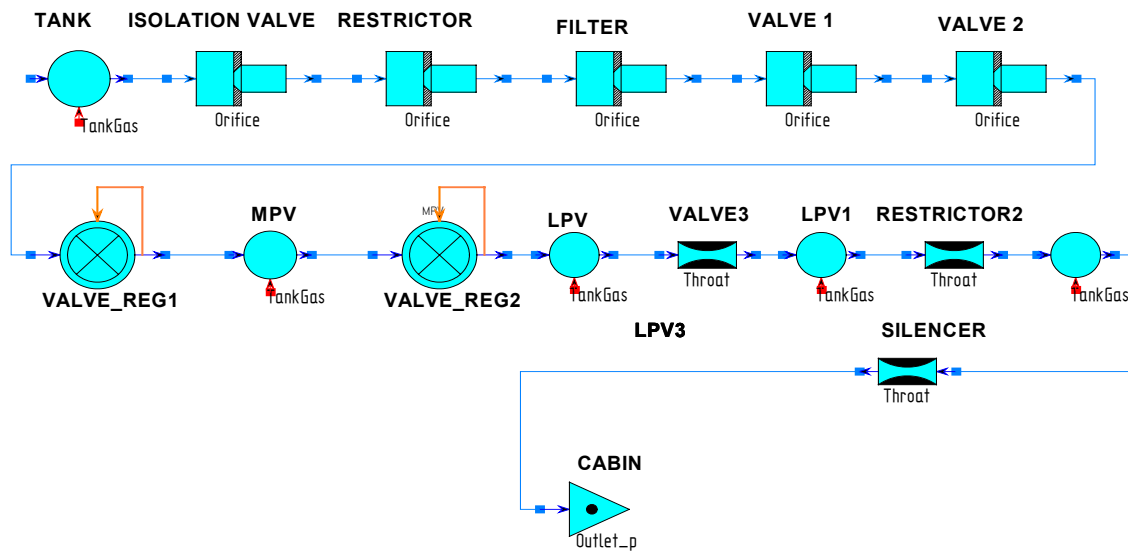

Figure 4 — EcosimPro model of ATV O2 delivery

- Determination of gas pressure, temperature and velocity profiles along the gas distribution line

The storage conditions of the oxygen and nitrogen in the tanks are:

- Oxygen: Stored @ $p=214$ bar, $T=50$ °C
- Nitrogen: Stored @ $p=280$ bar, $T=50$ °C

A modification required for this analysis due to the high pressure in the tanks was to implement the real gas properties of N2 & O2 in the ECLSS Library. Tables of properties for these two gases were generated in files and a set of Fortran routines interpolating into the tables were implemented.

The model of O2 delivery line, which includes two pressure regulators is shown in figure 4.

Oxygen delivery is shown for a long transient (duration: 4000 s) in figure 5. The delivered mass flow rate is within the imposed requirement ($1.3 \div 2.3$ g/s) thanks to the combined action of the two pressure regulators, with a maximum reached flow rate equal to 2.13 g/s.

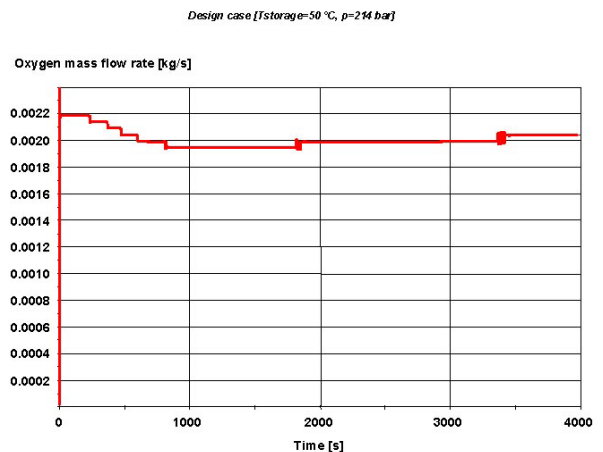

Figure 5 - Mass flow of ATV O2 delivery

ECOSIMPRO APPLICATIONS TO CELSS

The Micro-Ecological Life Support Alternative (Melissa) is a microorganism and higher plants-based ecosystem intended as a tool to gain understanding of the behavior of artificial ecosystems, and for the development of the technology for a future biological life support system for long term manned space missions [3,4].

The Melissa project started in 1989. The following is a short description of the complete Melissa life support Loop.

The loop is conceived as five interconnected compartments, following the schema of figure 6.

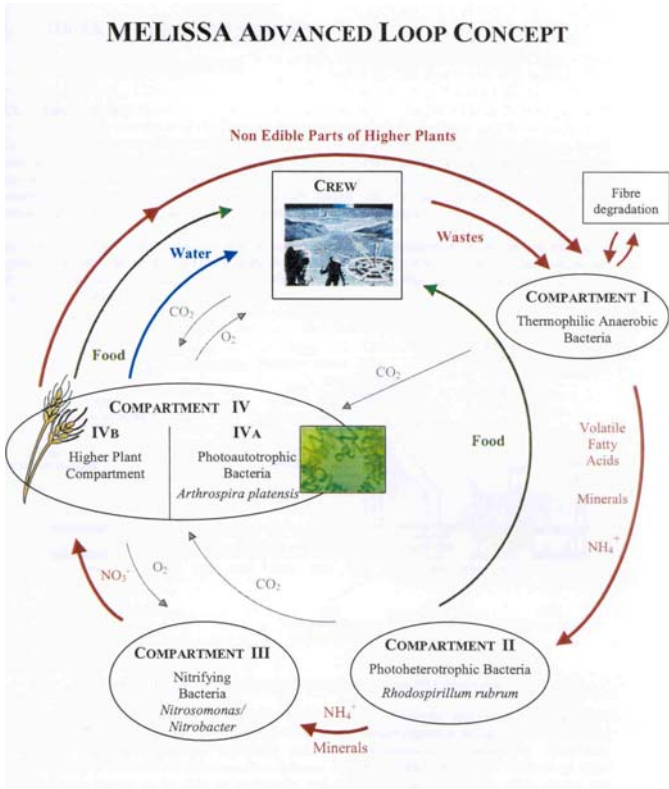

Figure 6 — Melissa Loop

In a first stage the waste (feces, urea and non-edible parts of plants), is treated by anaerobic bacteria (Compartment I) in order to reduce it to organic molecules of lower molecular weight. These molecules (mainly fatty acids) are degraded to CO₂ by Rhodobacter (Compartment II). The ammonia resulting from the degradation in Compartment I, needs to be oxidized to nitrate in order to be used by higher plants and photoautotrophic bacteria. This oxidation takes place in the Nitrifying Compartment (Compartment III). Photosynthesis occurs in Compartment IV, which is fed by the CO₂ coming from other compartments. Compartment V represents the crew, which consume O₂, H₂O and food, and produce CO₂, wastewater, urea and feces. The wastes feed the first compartment, closing the loop.

The standard ECLS Library of EcosimPro was designed having in mind the analysis of ventilation loops, and it is not well adapted to the analysis biologically based life-support systems.

The standard ECLSS Library takes into account the following phenomena:

- Balance of the pressure drops in the hydraulic circuits
- Storage of thermal energy by the fluid and the walls
- Condensation of air humidity
- Chemical reactions.

When modelling a bio-reactor, the following phenomena have to be accounted for:

- gas-liquid equilibrium
- acid-base equilibrium

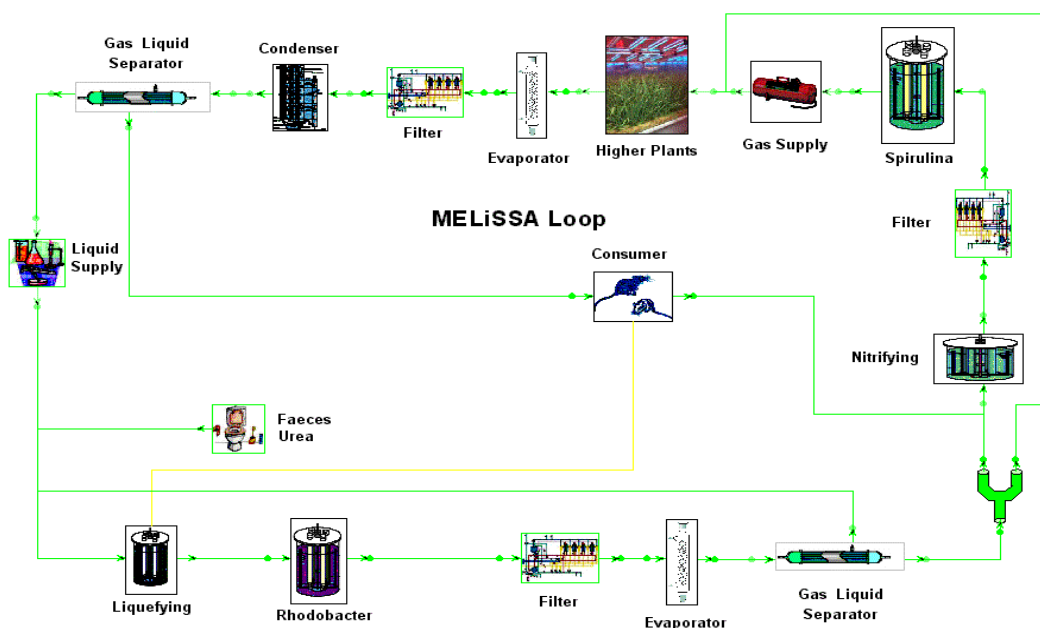

Figure 7 — EcosimPro Model of the Melissa loop

- finite rate of biological growth
- finite rate chemistry
- fluid dynamic interactions

A specific library of components was developed to model Melissa experiments. The main components of this library are:

- bio-reactors
- photo bio-reactor
- plant compartment, and predictive controller

This library could be expanded to represent other CELS systems outside of Melissa.

Figure 7 represents the EcosimPro model of the Melissa loop.

The EcosimPro model of the Melissa loop is being used for the following purposes:

- To understand the loop behavior
- To design the loop control system

Further details about the Melissa Simulations are reported in [7], where it is concluded that EcosimPro is well suited for simulating bio-regenerative life support system components and entire BLSS.

ECOSIMPRO APPLICATIONS TO ATCS

EcosimPro provides more flexibility than the traditional thermal analysis tools in representing phenomena that can not be properly represented by thermal nodes and thermal conductors. Examples of this kind of phenomena or behavior are fluid loops, control loops, ablation, etc. Two previous papers have explored the application of EcosimPro to thermal modeling [8,9].

The first paper describes how to apply EcosimPro to some medium size thermal network, while the second paper describes in detail the Refrigerator Freezer Rack of the Space Station.

ANALYSIS OF THE ISS RFR

The Refrigerator Freezer Rack (RFR) of the ISS will provide conditioned storage volume for astronaut food during transport in the MPLM and on board the ISS.

An EcosimPro model of the RFR (see figure 8) was developed to demonstrate the adequacy of EcosimPro to this kind of special thermal problem. The model includes a thermal network, but it also includes the representation of the following phenomena:

- Cooling effect of Peltier elements
- Convective heat transport by the an internal air loop
- Control of the cooling units

It was reported in [9] that EcosimPro was well suitable for the thermal modeling of this kind of application and could be efficiently used for detailed design and optimization of the RFR.

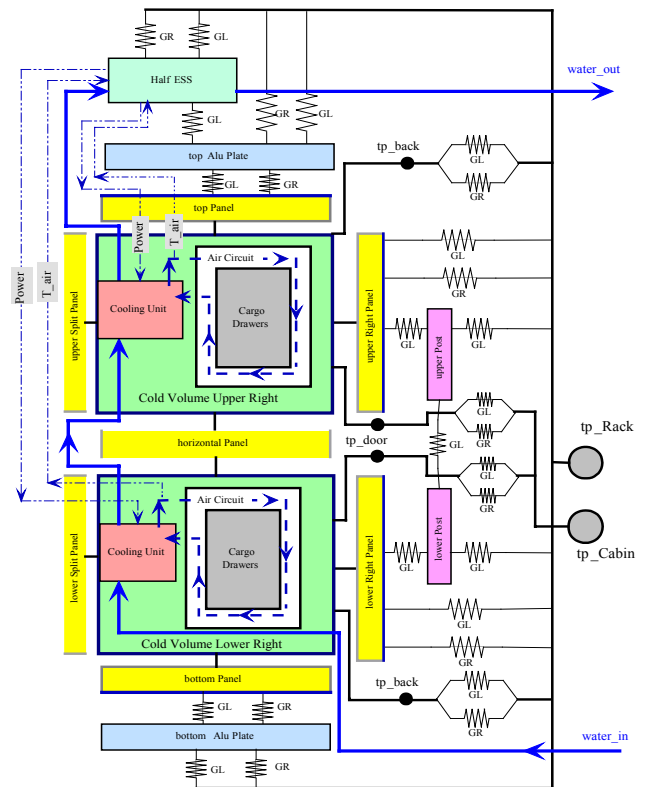

Figure 8 — RFR Thermal Model

CONCLUSION

EcosimPro is being used by the European space industry as the standard tool for ECLSS simulation. The standard ECLS library provided with EcosimPro covers rather well the modeling needs for the analysis of the air cabin loops.

The adaptability of EcosimPro has enabled the development by ESA/ESTEC of a specific library to simulate the Melissa experiments.

The flexibility of EcosimPro has extended its usage to the analysis of 1D dimensional flow problems, which are difficult for the current flow analyzers available in Thermal Software. This is the case of the analysis venting lines to vacuum and the gas delivery systems.

ACKNOWLEDGMENTS

Special thanks to Mr. Alexander Rodriguez and Mr Luis Ordóñez, both in ESA/ESTEC, Thermal and Structures Division, for their inputs about the Melissa models.

REFERENCES

1. "Hydraulic Analysis of the MPLM cabin loop using the software tool Ecosim". R. Forster et al., Sixth European Symposium on Space Environmental Control Systems, 20-22 May 1997, Noordwijk, The Netherlands, 972557
2. "Mode Transition Analyses of the Attached Pressurized Module Cabin Air Loop With EcosimPro", J. A. Romera Perez et al., ICES paper 2000-01-2366
3. "Extension to Sinda/Fluint and Esatan/Fhts for Transient Simulation of Air- Vapor in Pressurised Modules", Valter Perotto et al., ICES paper 2000-01-2521.
4. "MELISSA – a Microorganisms based model for CELSS Development", M. Mergay et al., Proceedings of the 3rd symposium on space thermal control & life support system, Noordwijk, The Netherlands, October 1988.
5. "MELISSA Final Report" ECT/FG/MMM/97.012, CH. Lasseur et al, July 2002
6. "Preliminary Static and Dynamic Analysis of Melissa Components Using EcosimPro", Luis Ordóñez & Alexander Rodriguez, 2^a Reunión de Usuarios de EcosimPro, UNED, Madrid, Febrero 2003 (<http://www.ecosimpro.com>)
7. "Application of EcosimPro to Bio-regenerative Life Support Components", Alexander Rodriguez et al., ICES 2003, paper 03ICES-33.
8. "Using EcosimPro for Thermal and Thermo-Hydraulic Analysis in ESA", Olivier Pin, ICES paper 2001-01-2409
9. "ISS Crew Refrigerator Freezer Rack-Comparing EcosimPro and Esatan Modelling", Roland Mueller et al., ICES paper 2002-01-2447

CONTACT

Ramón Pérez Vara.
Empresarios Agrupados
28015 Madrid
Spain
e-mail: rpv@empre.es
<http://www.ecosimpro.com>

DEFINITIONS, ACRONYMS, ABBREVIATIONS

APM: Attached Pressurized Module

ARS: Air Revitalization System

ATCS: Active Thermal Control System

ATV: Automated Transfer Vehicle

BLSS: Bio-regenerative life support systems

CDRA: Carbon Dioxide Reduction Assembly

CELSS: Controlled Ecological Life Support System

CHX: Condensing Heat Exchanger

ECLSS: Environmental Control and Life Support Systems

ESA: European Space Agency

ESTEC: European Space Research & Technology Centre

GDS: Gas and Delivery System

ISS: International Space Station

MPLM: Multi Purpose Logistic Module of the International Space Station

RFR: Refrigerator Freezer Rack