

C7

MODELLING AND SIMULATION OF DISTRIBUTED PROCESSES: DIFFUSERS IN THE SUGAR INDUSTRY

Merino Gómez, Alejandro

Centro de Tecnología Azucarera. Universidad de Valladolid

C/ Real de Burgos. Edificio Alfonso VIII. Planta baja s/n. 47011. Valladolid — Spain

Teléfono: 983 42 35 63. FAX: 983 42 36 16. Email: alejandro@cta.uva.es

Abstract

This paper describes how a diffuser used in the sugar industry has been modelled and simulated with EcosimPro. Because of its physical and operating characteristics, the mathematical model of this equipment can be described by partial derivatives which requires the discretization of the system. This work shows in a practical way how these types of problems can be resolved using EcosimPro.

Key words: Simulation, EcosimPro, distributed systems, mass and energy transfer.

1 INTRODUCTION

The objective of this work is to show how to model a system whose mathematical model of behaviour is represented by differential equations in partial derivatives.

First of all, the physical system is described in order to offer a better understanding of the process.

Later, an explanation will be given of the methodology followed to transform the EDP model into an ODE model.

This will be applied to a particular case: a diffuser in the sugar industry. The use of simulation for these types of systems will be justified and the mass and energy balances needed to model the system will be established.

Lastly, the results obtained through the simulation with EcosimPro will be presented.

2 DESCRIPTION OF THE PROCESS

Diffusion is one of the first stages in the beet sugar production process. The object of this stage is to extract the maximum amount of sugar from the beet

after it has been washed and cut into thin strips, called cossettes.

A countercurrent flow of hot water extracts the sugar from the cossettes.

It is essential that this stage be well designed because the maximum amount of sugar must be extracted using as little water as possible. This is why a method of countercurrent extraction is used, in which water with less sugar concentration is put in contact with cossettes with less sugar concentration so that the concentration gradient, which forces the mass transfer, is maximised at all times.

These operations are carried out in equipment known as diffusers. Although the process is governed by the same physical principles, there are different types of diffusers with different operating characteristics. In this case we are going to use the RT diffuser which is widely used in Spain.

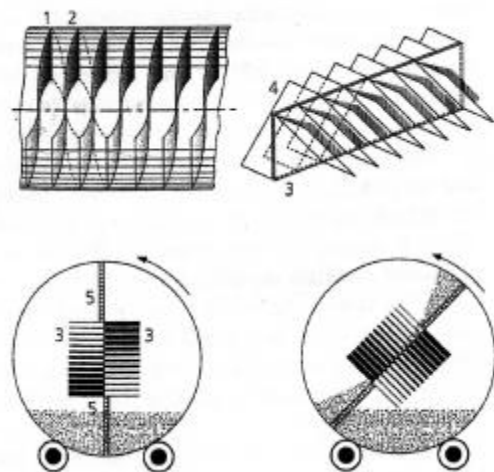

Figure 1. Elements comprising an RT 2 diffuser [1]

1 and 2 helicoidal plates which form two separate channels for the juice; 3 transversal plate; 4 chutes for the cossettes; 5 transverse screens.

This type of diffuser is comprised of some large rotating drums which are separated into cells by a propeller attached to the inner surface. As the drum with the propeller rotates, the juice that is left on the bottom is transported from the top of the diffuser to the bottom. In this way it is the cell that moves, although it would be more practical to consider that each cell is located at each rotation of the propeller. If the screw has 30 threads then the drum will have to rotate 30 times for the juice to travel from one side of the diffuser to the other, and it is considered that the diffuser has 30 cells. There are screens fixed to the cylinder and, as the drum rotates, they move the cosettes along until they drop into the next cell. In this way the juice and the cosettes move in opposite directions.

These diffusers are very big (up to 45 m long and 7 m in diameter) and very expensive, which means that the majority of factories therefore have only one. They are also indispensable in the sugar production process which makes empirical work with these types of systems very difficult. Consequently, the use of simulation for these kinds of systems is especially attractive.

3 DISCRETISATION OF A DISTRIBUTED PARAMETER SYSTEM

Global parameter systems are those in which the properties and the state variables of the system can be considered to be uniform throughout the system. In reality, all the systems are distributed because there are always spatial variations in the properties or variables. However, these variations are often small and can be ignored and we can therefore consider the model as a global parameter model.

On the other hand, there is a series of systems in which the spatial distribution of the properties requires the use of a distributed parameter model. They are usually systems in which the length-diameter ratio is very high and therefore the dependence of the variables on the length is very important. This is the case of a rotating diffuser in a sugar factory.

The mathematical equations that model the processes represented by a distributed parameter model are as follows:

$$\frac{\partial T}{\partial t} + \frac{\partial(v_z \cdot T)}{\partial z} = \text{Transporte} + \text{Generación} \quad (1)$$

The problem is that EcosimPro does not support differential equations in partial derivatives. We therefore transform the distributed parameter model by means of discretisation with respect to one of the variables and obtain an equation as follows:

$$\frac{dT_n}{dt} = v_z \cdot \frac{(T_{n-1} - T_n)}{\Delta z} + \text{Transporte} + \text{Generación} \quad (2)$$

This is equivalent to a series of global models connected together [2].

The connection of numerous global parameter models is made in such a way that the output from one element coincides with the input of the next element with a determined delay.

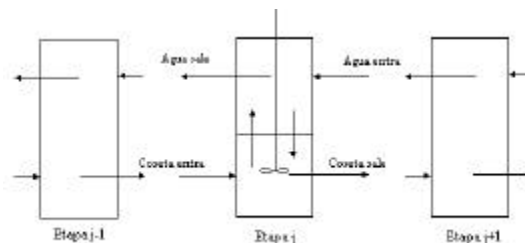

Figure 2

We therefore divide the diffuser into elements. Determining the number of elements is a matter of having to compromise between the precision of the calculation (the larger the number of elements, the closer the solution to that of distributed parameters) and the simulation time.

The number of elements was determined so that the final solution would not vary significantly when another element was put in or taken out.

The use of this technique turns out to be almost the same as the use of finite differences in the solution of the model.

4 DESCRIPTION OF THE MODEL

The diffuser is a difficult element to model because the phenomena that take place inside a diffuser are of a very complex nature. There are simultaneous mechanisms which transfer mass by diffusion owing to the concentration gradient, reverse osmosis phenomena and physical crushing phenomena. In addition, the mass and energy transfers are related because the diffusion constant is affected by the temperature and the temperature is affected by the speed of diffusion.

With respect to mass transfer, it was decided to opt for utmost simplification and to assume that mass transfer existed due only to the difference in the concentration of the juice and the concentration of the solution.

Apart from that explained above, it is assumed that the diffuser is divided into 20 equal cells in which the transfer of sugar, of non-sugars and of water takes place.

It is also assumed that:

The cells are connected in such a way that the output from one cell coincides exactly with the input to the next cell, in accordance with the direction of flow in each phase.

The total mass transfer from the diffuser is governed only by the expressions indicated hereinafter.

Each cell contains a perfect mix and, therefore, the value of the variables at the outlet will be equal to the value of the variables inside each cell.

There is a countercurrent flow between juice and cossettes throughout the whole diffuser. No consideration is given to axial dispersion.

Each step is delayed with respect to the previous step following a delay of the first order. The flow model therefore comprises 20 tanks that contain a perfect mix and are arranged in series, between each of which there is a delay of the first order.

The cossettes suffer an enthalpy variation which is due, on the one hand, to the difference in temperature (if it exists) between the cossette and the juice and, on the other hand, to the cossette/juice mass transfer.

The number of differential elements that exist has been parametrised by means of the “*net*” constant so that elements can be added or removed at will. The first and last elements are connected to the outside by means of ports so that the input conditions are imposed by the environment and the output conditions are imposed by diffuser operation.

The following is a schematic of the diffuser:

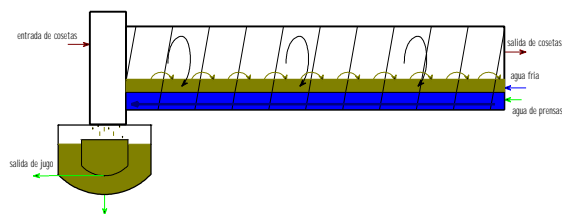

Figure 3

A simple description of how it operates would be that the extraction water enters on the right-hand side of the diffuser and flows to the left, extracting the sucrose and other unwanted substances as it flows through the cossettes which are moving from left to right.

The equations for each of the elements are given below:

4.1 MASS BALANCES

Mass transfer between the cossettes and the juice takes place in each of the diffuser cells.

To model the mass transfer, we will use the driving force linearity hypothesis.

Water transfer is brought about by replacing the sugar which is removed during the first stages of the process. The water variation inside a cell can therefore be calculated with the following equation:

$$W_{agt} = k_{ag} \cdot W_{azt} \quad (3)$$

The transfer of sugar and non-sugars is calculated in accordance with the design equation:

$$W_t = k \cdot (C_c - C_d) \quad (4)$$

The mass transfer constants are the result of the product of a mass transfer constant times an exchange area times the density.

The design of this diffuser also takes into account a series of factors which affects the transfer of sugar and non-sugars. The following are the factors taken into consideration:

- Temperature
- pH
- State of the cossettes
- Size of the cossettes
- Permeability of the cossettes
- Effect of the draft

To model the effects of these factors, it has been considered that they have a different effect on the mass transfer coefficient. A value has therefore been defined for the mass transfer constant multiplied by a series of factors that affects the diffusion. These factors will have a maximum value of 1 when their value is optimum and will decrease when the effect of the factor is such that mass transfer is impeded.

As an example, we are going to see how the effect of the temperature would be introduced into the model.

Effect of the temperature

The effect of the temperature is clear — the higher the temperature, the better the diffusion. In addition, a temperature greater than 50°C is required to achieve denaturalisation, and high temperatures also provide protection against bacteria.

The upper temperature limit is 75°C. At temperatures any higher than this, we run the risk of beet degradation.

The following graph shows the values of the factor at different temperatures:

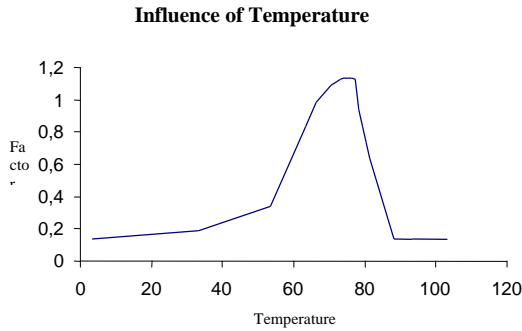

Figure 4

The introduction of these influence functions into EcosimPro is easy. A series of functions is created, into which we introduce known experimental data on the effects of different factors on the extraction and use the interpolation function *linearInterp1D*.

The following is an example of one of the influence functions introduced into the model.

```

-----
FUNCTION REAL Inf_temp (IN REAL T)
DECLS
  REAL ltemp
  CONST TABLE_1D inf_temp= {{0, 30, 50, 60,\
63, 67, 70, 71, 72,73,74, 75, 76, 77, 78,\
85,90,100},
{0.,0.05,0.2,0.7,0.85,0.95,0.99,1.,1.,\
1, 0.99,0.8,0.7,0.6,0.5,0.,0.,0.}}
BODY
  ltemp=linearInterp1D(inf_temp,T)
  RETURN ltemp
END FUNCTION
-----

```

4.1.1 SUGAR BALANCE

In the cosettes

$$\frac{dm_{caz}}{dt} = W_{ce} \cdot C_{caze} - W_{cs} \cdot C_{cazs} - W_{aztransf} \quad (5)$$

$$W_{aztransf} = k_{az} \cdot (C_{caz} - C_{daz}) \quad (6)$$

$$m_{caz} = m_c \cdot C_{caz} \quad (7)$$

In the solution

$$\frac{dm_{daz}}{dt} = W_{de} \cdot C_{daze} - W_{ds} \cdot C_{dazs} + W_{aztransf} \quad (8)$$

$$m_{daz} = m_d \cdot C_{daz} \quad (9)$$

4.1.2 NON-SUGARS BALANCE

In the cosettes

$$\frac{dm_{cnaz}}{dt} = W_{ce} \cdot C_{cnaze} - W_{cs} \cdot C_{cnazs} - W_{naztransf} \quad (10)$$

$$W_{naztransf} = k_{naz} \cdot (C_{cnaz} - C_{dnaz}) \quad (11)$$

$$m_{cnaz} = m_c \cdot C_{cnaz} \quad (12)$$

In the solution

$$\frac{dm_{dnaz}}{dt} = W_{de} \cdot C_{dnaze} - W_{ds} \cdot C_{dnazs} + W_{naztransf} \quad (13)$$

$$m_{dnaz} = m_d \cdot C_{dnaz} \quad (14)$$

4.1.3 WATER BALANCE

In the cosettes

$$\frac{dm_{cag}}{dt} = W_{ce} \cdot C_{cage} - W_{cs} \cdot C_{cags} - W_{agtransf} \quad (15)$$

$$W_{agtransf} = k_{ag} \cdot W_{aztransf} \quad (16)$$

$$m_{cag} = m_c \cdot C_{cag} \quad (17)$$

In the solution

$$\frac{dm_{daz}}{dt} = W_{de} \cdot C_{dage} - W_{ds} \cdot C_{dags} + W_{agtransf} \quad (18)$$

$$m_{daz} = m_d \cdot C_{daz} \quad (19)$$

4.2 FLOWS

The mass flows of cosettes and solution produced at each stage are evaluated assuming that they are proportional to the masses that exist in each element, multiplied by a constant and by the speed of the rotor in rpm.

In the variables that flow through the system we have introduced a delay between stages so that the delay in transport that takes place inside the diffuser is taken into account and the changes in an element take a certain amount of time to affect the subsequent stages. This delay has been modelled with a function of the first order, as follows:

$$\tau \cdot \frac{dX_{je}}{dt} = X_{(j-1)s} - X_{je} \quad (20)$$

Where X_{je} is the value of the variable X at the inlet of stage j, $X_{(j-1)s}$ is the value of the same variable at the outlet of the previous stage and τ is the time constant, it is a measurement of delay.

4.3 ENERGY BALANCES

In the same way as described in the previous section, we calculate the energy balances for each differential element of the diffuser.

As explained before, the enthalpy variation which the cossette suffers is due, on the one hand, to the difference in temperature (if it exists) between the cossette and the juice and, on the other hand, to the cossette/juice mass transfer. We therefore have a simultaneous phenomenon of energy and mass transfer. The energy balance equations are those shown below:

Cossette

$$\frac{d(m_c \cdot H_c)}{dt} = W_{ce} \cdot H_{ce} - W_{cs} \cdot H_{cs} - H_{tm} + H_{tc} \quad (21)$$

Juice

$$\frac{d(m_d \cdot H_d)}{dt} = W_{de} \cdot H_{de} - W_{ds} \cdot H_{ds} + H_{tm} - H_{tc} \quad (22)$$

The following are the equations to calculate the flow of heat due to mass transfer:

$$H_{tm} = (m_{azt} + m_{agt} + m_{marct}) \cdot H_c \quad (23)$$

That is, the product of the mass which is being transferred, and the enthalpy of the cossette at its temperature. By using this expression, any other type of solution enthalpy is disregarded.

The energy transferred by the difference in temperatures is calculated by means of the following expression:

$$H_{tc} = k_c (T_d - T_c) \quad (24)$$

Where k_c is a constant which encompasses the overall cossette-solution heat transmission coefficient and the area of exchange.

5 MODEL DEVELOPMENT IN ECOSIMPRO

All these equations have been incorporated into EcosimPro, along with other necessary related equations.

Programming these types of systems is easy because the statements EXPAND or EXPAND_BLOCK allow the insertion of numerous equations based on a parameter which is modified. This has two advantages: it decreases the amount of code and we can parameterise the size of the set of equations which is created. The latter is especially useful in this case because discretisation can be expanded or contracted with the use of a single parameter.

The following is an example of the use in the diffuser model of EXPAND_BLOCK.

```

-----
EXPAND_BLOCK(j IN 1,net)
    Ccaz[j] = zona(mcaz[j],mc[j],0.)
    Cdaz[j] = zona(mdaz[j],md[j],0.)
    maza[j] = max((k1_real[j] * (Ccaz[j] - Cdaz[j])),0)
    mcaz[j]' = Wce[j] * Ccaze[j] - Wcs[j] * Ccazs[j] -
--"Balance al azúcar in the cossettes"
    mdaz[j]' = Wde[j] * Cdaze[j] - Wds[j] * Cdazs[j] +
--"Balance al azúcar in the disolución"
    maza[j]
    tauWc * Ccazs[j]' = Ccaz[j] - Ccazs[j]
    tauWd * Cdazs[j]' = Cdaz[j] - Cdazs[j]
END EXPAND_BLOCK
-----

```

The diffuser communicates with the exterior by means of five ports

IN	solido (Mix=cossette)	in_cos
OUT	solido (Mix=cossette)	out_cos
IN	f_juice (Mix=juice)	in_agua_prens
IN	liquido (Mix=H2O)	in_agua_apt
OUT	f_juice (Mix=juice)	out_dis
IN	analog_signal	u_rot
OUT	analog_signal	v_c

There are two IN ports for the solution which will extract the sucrose, one OUT port for the sucrose-rich juice, one OUT port for the exhausted pulp, and one analogue IN port and OUT port which are connected to a controller that regulates the diffuser rotation speed.

6 SIMULATION OF THE DIFFUSER

In the following paragraphs we will see how the diffuser responds to different disturbances.

A number of stages equal to 20 has been used in the simulation.

In the first place, the parameters of the model have been adjusted so that the responses are realistic.

The process is then simulated and, from the points of view of mass flows and concentrations, an analysis is made of the results obtained by means of simulation as compared with the real data that we have.

The following are the values of the extraction juice obtained at the outlet of the diffuser:

Outlet Juice		
Substance	% weight simulation	% weight theoretical
Sugar	13.65	13.86
Non-sugar solubles	1.77	1.77
Total dry substance	15.42	15.64
Water content	84.35	84.56
Outlet mass	91.53	91.61

Table 1

While the values for the exhausted pulp that is discharged from the diffuser are:

Outlet Juice		
Substance	% weight simulation	% weight theoretical
Sugar	3.85	3.55
Non-sugar solubles	0.70	0.69
Frame	5.60	5.60
Total dry substance	10.15	9.84
Water content	89.84	90.16
Outlet mass	60.68	60.75

Table 2

To see how the sugar concentration evolves, the following graph shows the sugar concentrations in the juice and in the cossette along the length of the diffuser:

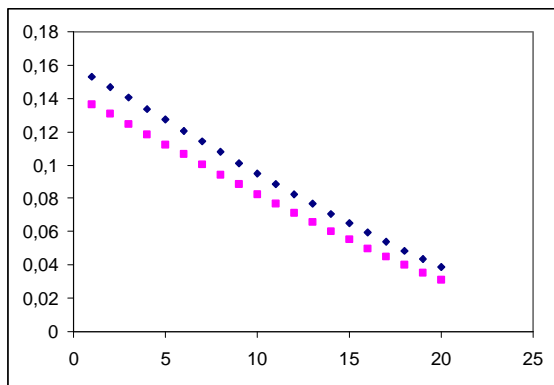

Figure 5

- ◆ Sugar concentration in the juice in percentage weight vs. discretised length of diffuser.
- Sugar concentration in the cossette in percentage weight vs. discretised length of diffuser.

Figure 5 shows a typical profile in the case of countercurrent extraction, where the concentration difference is kept more or less constant throughout the complete extraction process, decreasing slightly as the cossette loses its sugar content.

The following describes how the sugar concentration in different parts of the diffuser are affected by a variation in the flow of refresh water that is being added. The water flow varies from 24.20 kg/s up to 32.40 kg/s. The graph shows discretisation points 1, 5, 10, 15 and 20. By default in the experiments, the x axis represents the time in h.

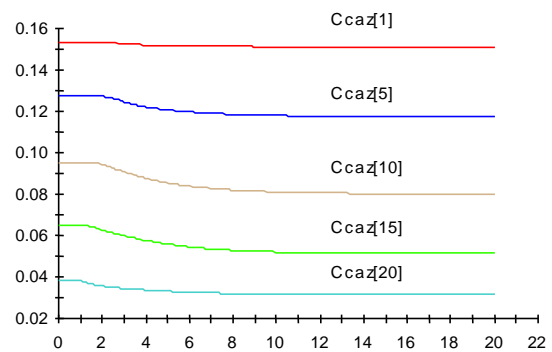

Figure 6

It can be seen that as soon as there is any disturbance, the sugar concentration at the first point decreases. The change at the remaining points takes place with a certain delay because they are further away from the point at which the disturbance takes place.

It can also be seen how the flow model behaves if we add the derivative of the concentration with respect to time.

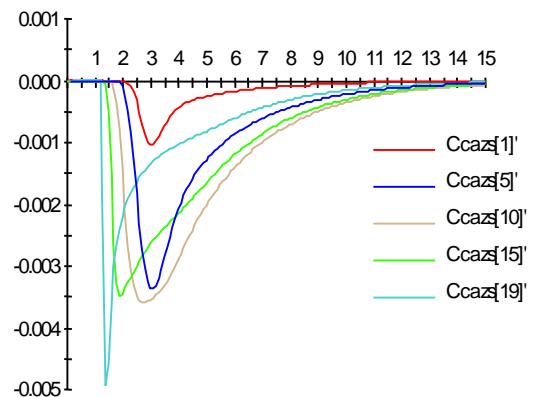

Figure 7

It can be seen that the further the peaks are from the disturbance, the lower and more symmetrical they become. This corresponds with the results obtained if we connect n tanks in series.

Let us see what happens if, due to heater failure, the cossettes enter at 15°C instead of 69°C.

Figure 8 shows how the temperature of the juice decreases along the length of the diffuser as it makes contact with the cold cossettes.

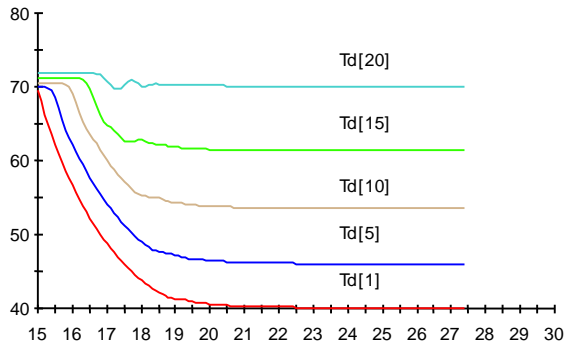

Figure 8

It can be seen how the sugar concentration in the cossette increases as the temperature goes down, especially during the first stages where the temperature is at its lowest. The sharp peaks show where there has been a sudden change in the temperature. In reality, however, these peaks would not occur in this fashion and the response would be smoother.

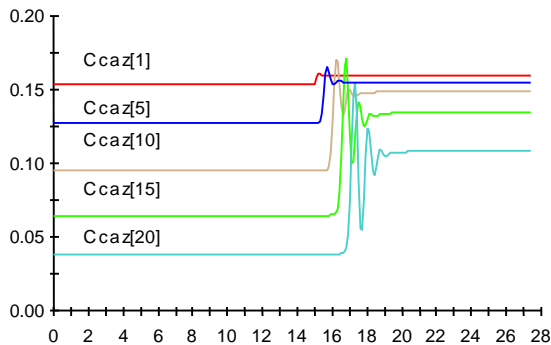

Figure 9

We can carry out a three-dimensional analysis of what happens. Figure 10 shows the variation in the sugar concentration with time and with distance as the quantity of water added to the diffuser is increased.

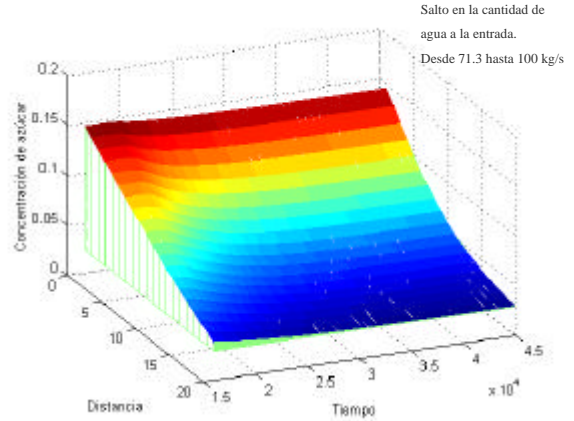

Figure 10

7 PORTS AND PHYSICAL PROPERTIES

To develop this component we have created a series of auxiliary libraries for physical properties and for ports.

As an example of ports, the following is the juice port which was created to connect the juice inlet and outlet of the diffuser with other components.

PORT f_juice (SET_OF(Chemical)Mix)

```

SUM REAL W "Flujo másico (Kg/s)"
SUM IN REAL Wi[Mix] "Flujo másico de cada
componente (Kg/s)"
EQUAL OUT REAL C[Mix] "Concentraciones (%1 en
peso)"
EQUAL REAL P "Presión (bar)"
REAL T "Temperatura (°C)"
EQUAL OUT REAL H "Entalpía específica KJ/Kg"
SUM IN REAL f_energ "Flujo de entalpía (KJ/s)"
REAL Pol "Polaridad en %1 en peso"
REAL Pureza "Pureza en %1 en peso"
REAL Brix "Grados Brix en %100 en
peso"
REAL Rho "Densidad (Kg/m^3)"
REAL F
EQUAL OUT REAL pH
    
```

CONTINUOUS

```

1 = SUM (j IN Mix; C[j])
EXPAND(j IN Mix EXCEPT setofElem(Mix,1)) Wi[j] = C[j] * W
W=SUM(j IN Mix;Wi[j])
Pureza = zona(Pol,max((Brix/100),0.01),0)
Pol = C[azucar]
Brix = 100 * (C[azucar]+C[no_azucar])
H = H_juice(T,Brix,Pureza)
f_energ = W * H
Rho = Den_juice(T,Brix,Pureza)
W=F*Rho

```

END PORT

The following physical properties were included:

- Juice (conductivity, density, viscosity, steam pressure, enthalpy)
- Cossettes (enthalpy)
- Water (viscosity, density, enthalpy)

8 PROBLEM EXTENSION

The diffuser is the central part of the diffusion section. Although this section has not been described in this paper, it has been modelled in its entirety.

The following figure shows an image of the diffusion section obtained through the graphic connection of different components created with EcosimPro.

Graphic connection was made using the SmartSketch program which allows different components created with EcosimPro to be quickly connected. It also generates the simulation code of the complete assembly.

Figure 11 shows the result of the connection of all the components.

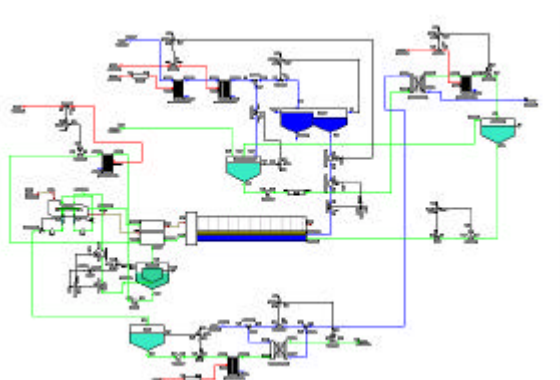

Figure 11

Nomenclature

C_c	concentration in the cossette expressed as a ratio per unit weight.
C_{cag}	water concentration in the cossettes inside the differential element, expressed as a ratio per unit weight.
C_{cage}	water concentration in the cossettes at the inlet expressed as a ratio per unit weight.
C_{cags}	water concentration in the cossettes at the outlet expressed as a ratio per unit weight.
C_{caz}	sugar concentration in the cossettes inside the differential element expressed as a ratio per unit weight.
C_{caze}	sugar concentration in the cossettes at the inlet of the element expressed as a ratio per unit weight.
C_{cazs}	sugar concentration in the cossettes at the outlet of the element expressed as a ratio per unit weight.
C_{cnaz}	concentration of non-sugars in the cossettes inside the differential element expressed as a ratio per unit weight.
C_{cnaze}	concentration of non-sugars in the cossettes at the inlet expressed as a ratio per unit weight.
C_{cnazs}	concentration of non-sugars in the cossettes at the outlet expressed as a ratio per unit weight.
C_d	concentration in the solution expressed as a ratio per unit weight.
C_{dag}	water concentration in the solution inside the differential element expressed as a ratio per unit weight.
C_{dage}	water concentration in the solution at the inlet of the element expressed as a ratio per unit weight.
C_{dags}	water concentration in the solution at the outlet of the element expressed as a ratio per unit weight.
C_{daz}	water concentration in the solution inside the differential element expressed as a ratio per unit weight.
C_{daze}	sugar concentration in the solution at the inlet of the element expressed as a ratio per unit weight.
C_{dazs}	sugar concentration in the solution at the outlet expressed as a ratio per unit weight.
C_{dnaz}	concentration of non-sugars in the solution inside the differential element expressed as a ratio per unit weight.
C_{dnazs}	concentration of non-sugars in the solution at the inlet of the element expressed as a ratio per unit weight.

C_{dazs}	concentration of non-sugars in the solution at the outlet of the element expressed as a ratio per unit weight.	W_{ce}	mass flow of cossettes which enters the element, kg/s.
H_c	specific enthalpy of the cossette inside each cell, in kJ/kg.	W_{cs}	mass flow of cossettes which is discharged from the element, kg/s.
H_{ce}	specific enthalpy of the cossette at the inlet of each cell, in kJ/kg.	W_{de}	mass flow of solution which enters the element, kg/s.
H_{cs}	specific enthalpy of the cossette at the outlet of each cell, in kJ/kg.	W_{ds}	mass flow of solution which is discharged from the element, kg/s.
H_j	specific enthalpy of the juice inside each stage, in kJ/kg.	$W_{naztransf}$	mass flow of non-sugars which is transferred inside the element, kg/s.
H_{je}	specific enthalpy of the juice at the inlet of each stage, in kJ/kg.		
H_{js}	specific enthalpy of the juice at the outlet of each stage, in kJ/kg.		
H_{tc}	enthalpy transferred from the juice to the cossette due to the effect of the temperature difference, in kJ/kg.		
H_{tm}	enthalpy transferred from the cossette to the juice due to the effect of mass transfer, in kJ/kg.		
k_{ag}	proportionality constant, which is adimensional.		
k_{az}	mass transfer coefficient for the sugar, in kg/s.		
k_{naz}	mass transfer coefficient for non-sugars, in kg/s.		
m_{agt}	mass flow of water which is transferred from the cossettes to the juice, in kg/s.		
m_{azt}	mass flow of sugar mass which is transferred from the cossettes to the juice, in kg/s.		
m_c	cossette mass inside the differential element, kg.		
m_{cag}	water mass in the cossettes inside the differential element, kg.		
m_{caz}	sugar mass in the cossettes inside the differential element, kg.		
m_{cnaz}	non-sugar mass in the cossettes inside the differential element, kg.		
m_d	solution mass inside the differential element, kg.		
m_{dag}	water mass in the solution inside the differential element, kg.		
m_{daz}	sugar mass in the solution inside the differential element, kg.		
m_{dnaz}	non-sugar mass in the solution inside the differential element, kg.		
m_t	mass of sugar or non-sugars which is transferred, in kg.		
$W_{agtransf}$	mass flow of water which is transferred inside the element, kg/s.		
$W_{aztransf}$	mass flow of sugar which is transferred inside the element, kg/s.		

Acknowledgements

This work has been carried out within the framework of the project “Simulation of sugar factories to optimise the process and personnel training” (FEDER TAP 1FD97-1450) carried out at the “Centro de Tecnología Azucarera” (Sugar Technology Centre) of the University of Valladolid. The author thanks all the persons involved in the project.

References

- [1] Sugar Technology. Beet and Cane Sugar Manufacture
P.W. van der Poel, H. Schiweck, T. Schwartz
Bartens 1998
- [2] Analysis and Simulation of Processes
David M. Himmelblau, Kenneth B. Bischoff
Reverté S.A. 1986
- [3] Heat and Mass Transfer
Eckert, E. R. G. y Dake, R.M.
McGraw Hill, 2nd edition 1959
- [3] Manual de energía para fábricas de azúcar
Tone Baloh, Enrique Wittwer
Ed Bartens, 2^a Edición
- [4] Beet-Sugar Technology
R. A. Mc Ginnis
Beet Sugar Development Foundation
3rd edition

